

Service
Service
Service



Service Manual

COMPACT
disc
DIGITAL AUDIO

CONTENTS

- 1 Explanation of the layout
- 2 Controls and technical specification
- 3 Servicing hints
- 4 Exploded view
- 5 Measurements and adjustments
- 6 Circuit diagrams, power supply, voltage adapter
- 7 Control & display panel
- 8 Wiring diagram, Voltage adapter
- 9 Electrical parts list
- 10 List of symbols

(GB)

Safety regulations require that the set be restored to its original condition and that parts which are identical with those specified be used.

(NL)

Veiligheidsbepalingen vereisen, dat het apparaat in zijn oorspronkelijke toestand wordt teruggebracht en dat onderdelen, identiek aan de gespecificeerde worden toegepast.

(D)

Bei jeder Reparatur sind die geltenden Sicherheitsvorschriften zu beachten. Der Originalzustand des Geräts darf nicht verändert werden für Reparaturen sind Original-Ersatzteile zu verwenden.

(I)

Le norme di sicurezza esigono che l'apparecchio venga rimesso nelle condizioni originali e che siano utilizzati pezzi di ricambio identici a quelli specificati.

(F)

Les normes de sécurité exigent que l'appareil soit remis à l'état d'origine et que soient utilisées les pièces de rechange identiques à celles spécifiées.

CLASS 1
LASER PRODUCT

3122 110 03420

MARANTZ DESIGN AND SERVICE

Using superior design and selected high grade components, MARANTZ company has created the ultimate in stereo sound.

Only **original MARANTZ parts** can insure that your MARANTZ product will continue to perform to the specifications for which it is famous.

Parts for your MARANTZ equipment are generally available to our National Marantz Subsidiary or Agent.

ORDERING PARTS:

Parts can be ordered either by mail or by telex. In both cases, correct part number has to be specified. The following information must be supplied to eliminate delays in processing your order:

1. Complete address
2. Complete part numbers and quantities required
3. Description of parts
4. Model number for which part is required
5. Way of shipment
6. Signature: any order form or telex must be signed otherwise such part order will be considered as null and void.

PARTS ORDERING

Parts may be ordered at the following addresses:

AUSTRIA
HORNYPHON
Vertriebsgesellschaft GmbH
Wienerbergstrasse 1
A 1101 Wien
Austria
Telex: 132.332

BELGIUM
SVD DIVISION MARANTZ
Industrialaan 1
1720 Groot-Bijgaarden
Belgium
Telex: 24466

CHILE
MARANTZ
DIVISION OF PHILIPS S.A.
AV. Santa Maria, 0760
Casilla 2687
Santiago
Telex: 240.239

DENMARK
MARANTZ
DIVISION OF PHILIPS
SERVICE A/S
Prags Boulevard 80
Postbox 1919
DK-2300 København S
Denmark
Telex: 31201

FINLAND
MARANTZ
DIVISION OF OY PHILIPS Ab
Kaivokatu 8
00100 Helsinki
Finland
Telex: 124811

FRANCE
MARANTZ FRANCE
4 Rue Bernard Palissy
92600 Asnières
France
Telex: 611651

GERMANY
MARANTZ GERMANY GmbH
Max-Planck-Strasse 22
6072 Dreieich 1
Germany
Telex: 529821

THE NETHERLANDS
Elpro Marantz
Wint Hontlaan 28
3526 KV Utrecht
The Netherlands
Telex: 4748

NORWAY
MARANTZ
DIVISION OF PHILIPS A/S
Sandstuveien 40
0680 Oslo 6
Norway
Telex: 72640

GREAT BRITAIN
MARANTZ AUDIO U.K. Ltd
Unit 15/16
Saxon Way Industrial Estate
Moor Lane
Harmondsworth UB7 OLW
Great Britain
Telex: 935196

GREECE
SHERTON ELECTRONICS S.A.
P.O.Box 21025
Hippocratus Street 188
Athens 11471
Greece
Telex: 216.795

JAPAN
MARANTZ JAPAN, Inc.
35-1, 7-chome, Sagamiono
Sagamihara-shi, Kanagawa
Japan

KUWAIT
AL ALAMIAH ELECTRONICS
Ussama Building
Fahd al Saleem Street
P.O.Box 23781
Safat-Kuwait
Telex: 22694

ITALY
MARANTZ ITALIANA S.P.A.
Via Chiese, 74
20126 Milano
Italy

SAUDI ARABIA
AL ALAMIAH ELECTRONICS
P.O.Box 5954
University Street
Riyadh 11432
Saudi Arabia
Telex: 401530

SOUTH AFRICA
MARANTZ
DIVISION OF PHILIPS S.A.
Main Road Martindale
P.O. Box. 58088
Newville 21114
South Africa

SPAIN
PHONO S.A.
Ignacio Iglesias 10
Badalona (Barcelona)
Spain
Telex: 59355

SWEDEN
MARANTZ
DIVISION OF PHILIPS
Försäljning AB
Tegeluddsvägen 1
S-115 84 Stockholm
Sweden
Telex: 14060

SWITZERLAND
DYNVOX ELECTRONICS
Route de Villars 105
1701 Fribourg
Switzerland
Telex: 942377

TURKEY
DOGRUOL Ltd.
I.M.C.
6 Blok N°6310
Unkapani
Istanbul
Turkey
Telex: 22085

MALTA
CACHIA & GALEA
Republic Street, 68D
Valetta
Telex: 1682

PORTUGAL
MARANTZ
Divisao philips S.A. service
Outurela-carnaxide
2795 LinDA-A-VELHA
Telex: 43906

MARANTZ INTERNATIONAL
Vestdijk 9
5600 MD Eindhoven
The Netherlands
Phone: +31/40.758290
Telefax: +31/40.75.82.99
Telex: 35000 PHTC NL routing IND NLMTFAT

All of the above locations are fully equipped to take care of your total service needs. Because various countries have differing configuration requirements, it is necessary that you contact the service facility in your particular country. In the event that there is no service location listed for your country, please, contact the nearest facility for the necessary assistance.

In case of difficulties, do not hesitate to contact the Technical Department at abovementioned address.

1. EXPLANATION OF THE LAYOUT OF THE DOCUMENTATION

The documentation consists of chapters.
 The number of the chapter is indicated by the first digit of the page number.
 The second digit of the page number is the sequence numbering.

If modifications or supplements require new supplementary or replacement pages, the page number is extended with a third part:

A digit behind the page number indicates that it concerns a supplementary page.
 A replacement page is indicated by a letter behind the page number.
Example

3-6 is page 6 of chapter 3
 3-6-1 is a supplementary page behind page 3-6
 3-6-a is the replacement page of page 3-6 (so page 3-6 can be removed from the documentation).

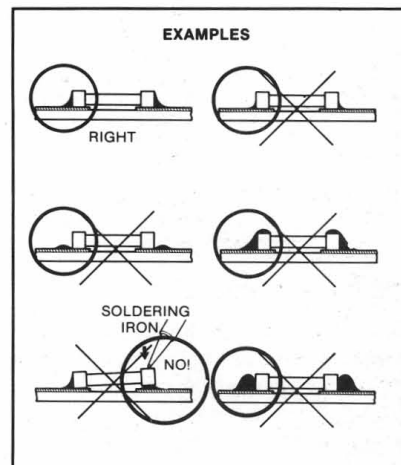
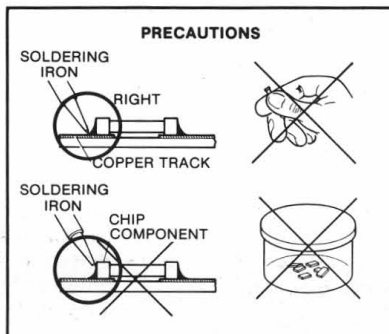
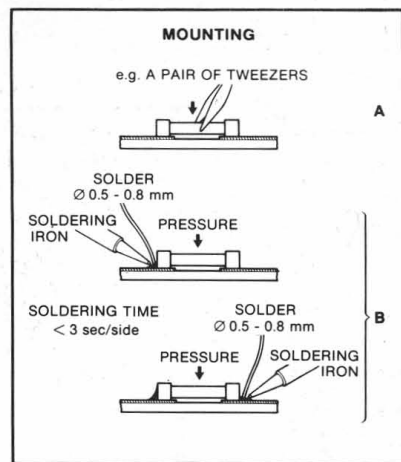
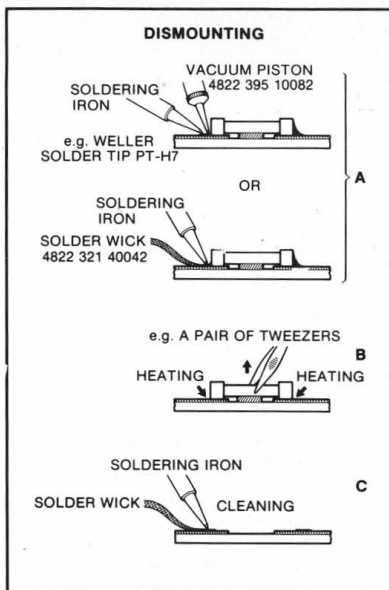
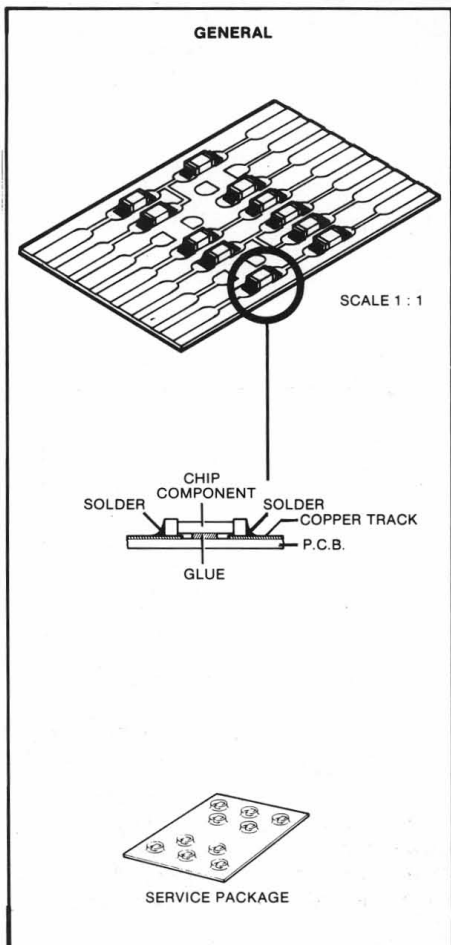

27 012C12

TECHNICAL SPECIFICATION

- System : Compact Disc Digital Audio system
- Disc diameter : 120mm/80mm
- Mainsvoltages/02/05 : 110 V, 127 V, 220 V, 240 V ± 10% (to be changed by transformer connections)
- /04 : 100 V ± 10%
- /06 : 117 V ± 10%
- /01 : 110 V, 127 V, 220 V ± 10% (to be changed by carousel switch)
- Mains frequencies : 50,60 Hz(no adaption required)
- Power consumption : ≤20 W
- Frequency range : 20 Hz + 20 kHz ±0,1 dB
- Output voltage fixed : max. 2 V_{rms}/≥10 kOhms
- Output impedance : 200 Ohms
- S/N ratio : ≥96 dB
- Channel separation : ≥93 dB
- Channel difference : ≤0,2 dB
- Total harmonic distortion : ≤-88 dB
- Intermodulation distortion : ≤-88 dB
- De-emphasis : 0 or 15/50 μs (switched by the subcode on the disc)
- Dimensions WxDxH : 454 x 118 x 288 mm (tray closed)
- Weight : approx 7 kg

CONTROLS

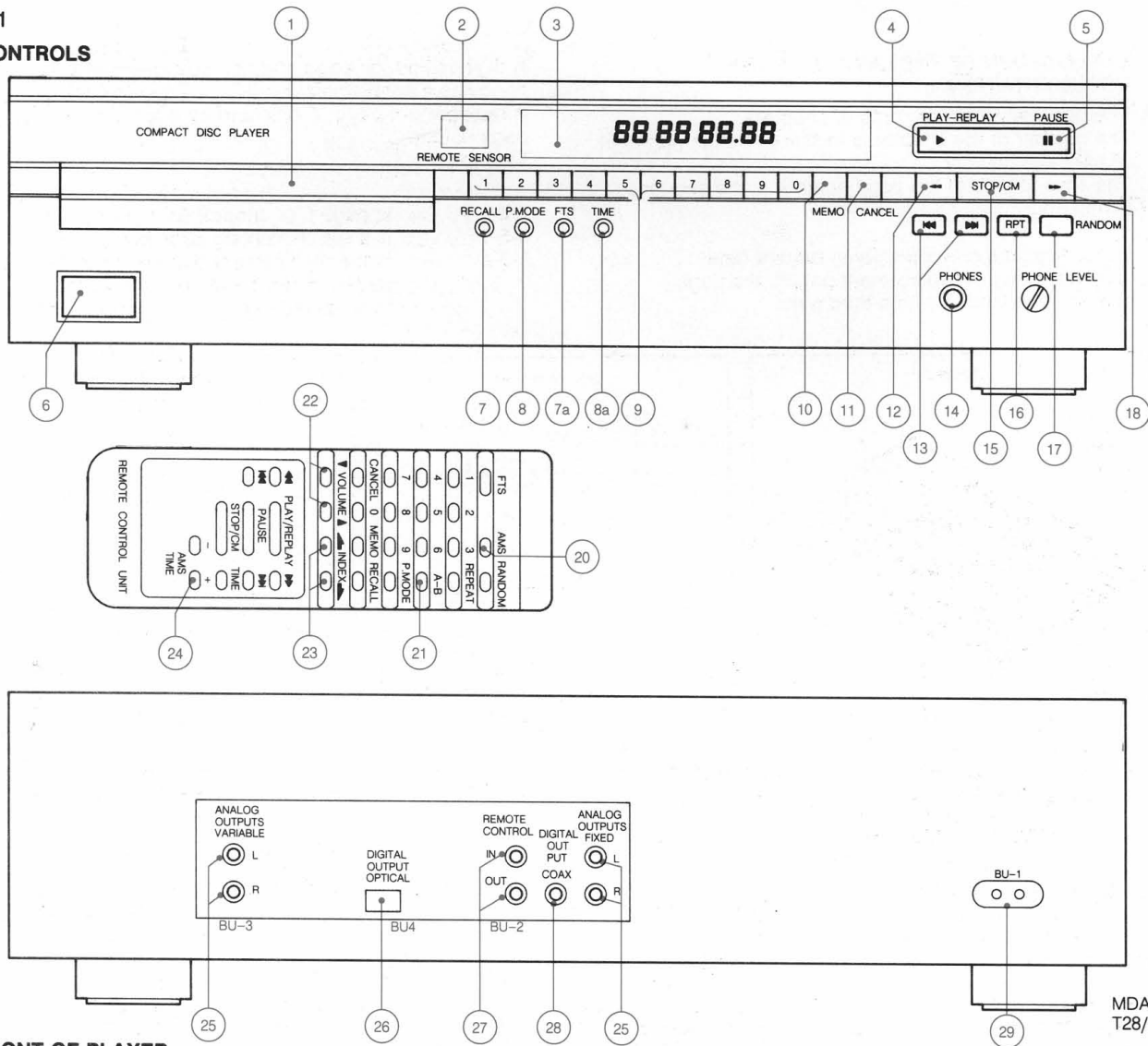

MDA.02172
T28/922

FRONT OF PLAYER

1 Disc tray on which the **OPEN** key is situated; the tray closes when the front is pressed briefly.

2 REMOTE SENSOR
Receives the signals from the remote control handset.

3 DISPLAY
- Informs you about the functioning of the player.
- Displays details from the disc contents list.

4 PLAY-REPLAY (▶)
- Starting play (**PLAY**)
- Returning to the beginning of a track (**REPLAY**)

5 PAUSE (II)
Interrupting play.

6 ON/OFF
Switching on and off.

7 RECALL
Reviewing a programme.

7a FTS
Activating the Favourite Track Selection circuit.

8 PROGRAM MODE
- Selecting **PROGRAM** mode when storing a program.
- Selecting **EDIT** mode to enter the recording time when making a tape recording.

8a TIME
Selecting the time information you want to see:
- **REMAIN**: The remaining playing time of a track.
- **TOTAL REMAIN**: The remaining playing time of the entire disc or a program.
- The elapsed playing time of a track.

9 '1-0' digit keys

- Selecting another track number during play.
- Selecting a track number to start play with.
- Selecting track numbers when programming.
- Entering the recording time when making a tape recording.

10 MEMO
- Storing track numbers in a program.
- Storing the recording time when making a tape recording.

11 CANCEL
- Erasing track numbers you do not wish to include in a program.
- Erasing track numbers from a program.
- Erasing favourite track selections.

12 ◀◀
Fast search for a particular passage; backwards to the beginning of the disc.

13 ◀▶
- Selecting another track number during play.
- Selecting a track number to start play with.
- Selecting track numbers when programming. (◀◀ from high to low; ▶▶ from low to high).

14 PHONES BU-5
Connecting headphones.

15 STOP/CM
- Stopping play (**STOP**).
- Erasing a program (**CM** = Clear Memory).

16 RPT
Repeating a track, the entire disc or a program (**RPT** = repeat).

17 RANDOM

Playing in a random order.

18 ►►

Fast search for a particular passage; forwards to the end of the disc.

REMOTE CONTROL FUNCTIONS

Most of the controls also appear on the remote control handset. The functions below can only be operated using the remote control handset:

20 AMS

Automatically playing the beginning of each track (AMS = Automatic Music Scan).

21 A-B

Storing the start and stop points of a passage to be repeated.

22 ▼ VOLUME ▲

Adjusting the sound level when the player is connected via the **VARIABLE**-output to an amplifier or HiFi system without its own remote control (▼ from high to low; ▲ from low to high).

23 ◀ INDEX ▶

– Selecting another index number during play.
– Selecting an index number to start play with.
(◀ from high to low; ▶ from low to high).

24 – AMS TIME +

Setting the playing time when scanning the disc.

For the best reception of the signals from the remote control you should aim it as directly as possible at the **REMOTE SENSOR**.

CONNECTIONS REAR OF PLAYER

- All connections to the rear panel should be made with the power to the entire system switched off.
- To avoid cross-connection of channels, connect one plug at a time.

25 ANALOG OUTPUTS

VARIABLE (BU-3): For connection to an amplifier of HiFi system without its own remote control.

FIXED (BU-2 Line out L/R): For connection to a **MARANTZ** amplifier of HiFi system with its own remote control.

- Insert a red plug into the 'R' socket (right-hand channel) and the other plug into the 'L' socket (left-hand channel) of the **VARIABLE** output or the **FIXED** output. In the case of connection via the **VARIABLE** output, the sound level can be adjusted with the ▼ **VOLUME** ▲ keys on the remote control.
- Insert the two other plugs into the corresponding sockets of the CD or AUX input of your amplifier. You can also use the TUNER or TAPE IN connection, but *never* the PHONO input. This is not suitable for Compact Disc reproduction.

26 DIGITAL OUTPUT OPTICAL BU-2-Digital out

This output supplies a digital signal via an optical path; for this reason it can only be connected to a Digital Analog Converter, an amplifier with an optical digital input or a digital sound processor. For this use an optical lead.

To prevent dirt entering this output, it is covered with a little cap which should only be removed when the output is in use.

27 REMOTE CONTROL IN/OUT BU-2 RC5 IN/OUT

- For connecting up the equipment when you are incorporating the player in a **MARANTZ** HiFi system with its own remote control system. For this use the RC5 cable supplied.
- For connecting the remote control receiver **RC 55**, available as an accessory, if the siting of the changer prevents its **REMOTE SENSOR** from receiving the signals from the remote control directly.

28 DIGITAL OUTPUT COAX BU-4

For digital signal processign or future applications such as CD-I.

This output supplies a digital signal and can therefore only be connected to an input which is suitable for this signal. Use here a lead with one cinch plug on either end.

WARNING!

Never connect this socket to a non-digital input of an amplifier, suvh as AUX, CD, TAPE, PHONO, etc. This can damage the amplifier and the loudspeakers.

29 MAINS SOCKET

- Insert the plug of the mains lead into the Mains Socket.
- Connect the other end to your mains supply.

3

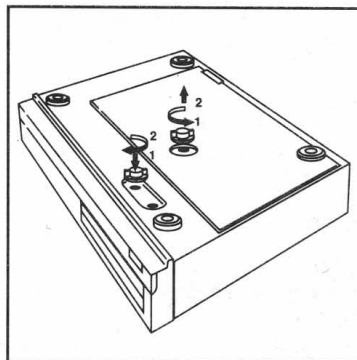

4 4 229 A11

REMOVING THE TRANSIT CLAMPS

The two red transit clamps on the underside of the player lock the player mechanism to secure it during transportation.

Remove these transit clamps before using the player. Store them in the recesses provided. Refit them before transporting the player.

3. SERVICING HINTS



All ICs and many other semi-conductors are susceptible to electrostatic discharges (ESD). Careless handling during repair can drastically reduce life expectancy.

When repairing, make sure that you are connected via a wrist wrap with resistance to the same potential as the chassis of the set. Keep components and aids also at the same potential.

When the tray mechanism and CDM-unit has been disassembled the player can be prepared for measurements by bridging the "tray detection" switch SK2 on the main panel.

Service disc hold-down

The disc should always rest properly on the turntable. To achieve this a disc hold-down has been mounted in a bracket of the tray mechanism.

If the tray mechanism has to be disassembled for servicing, a separate disc hold-down should be used. For a service disc hold-down see the figure below.

Compose a service Disc hold-down in the following way.

- Cut in the most inner ring of a disc holddown (4822 462 50383) with small and sharp nippers

See fig. below.

- Enlarge the diameter of the innermost ring slightly with the hind part of a pencil or ballpoint, so that it jams onto the turntable with sufficient force.

- If the jamming force decreases after certain time of use, the diameter has to be enlarged with a pencil or ballpoint again.

Explanation of the symbols used

- = oscilloscope (ri ≥ 10 MΩ)
- = meter (voltmeter with ri ≥ 10 MΩ)
- = carry out alignment/adjustment
- = test point

SERVICE DISC-HOLDDOWN

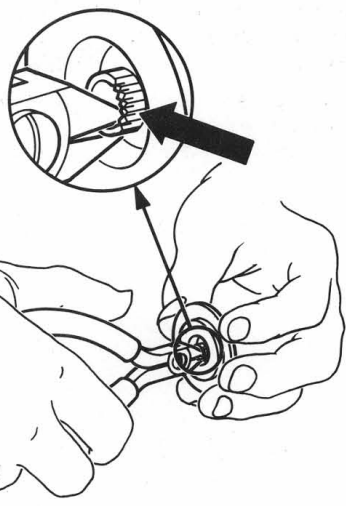

SERVICE TOOLS

Audio test disc 1	4822 397 30185
Disc without errors + black spots and fingerprints	4822 397 30096
Disc (65 min, 1kHz) without pause	4822 397 30155
Maximum diameter disc	4822 397 60141
Torx screwdrivers	
Set (straight)	4822 395 50145
Set (square)	4822 395 50132
13th order filter	4822 395 30204

WORKING WITH THE FAULTFINDING TREE

Follow the path of the faultfinding tree, beginning at the top left. Perform the actions you come across in the various blocks.

Look at the various side branches to find out if the information you see there applies to your problem. If, for instance, you find the indication display, this means that no picture appears on the display. If you establish this fault, follow the branch and perform the recommended actions. Check the components mentioned. In a number of branches further reference is made to measurements you could carry out. These measurements are explained in several tables further on in this manual.

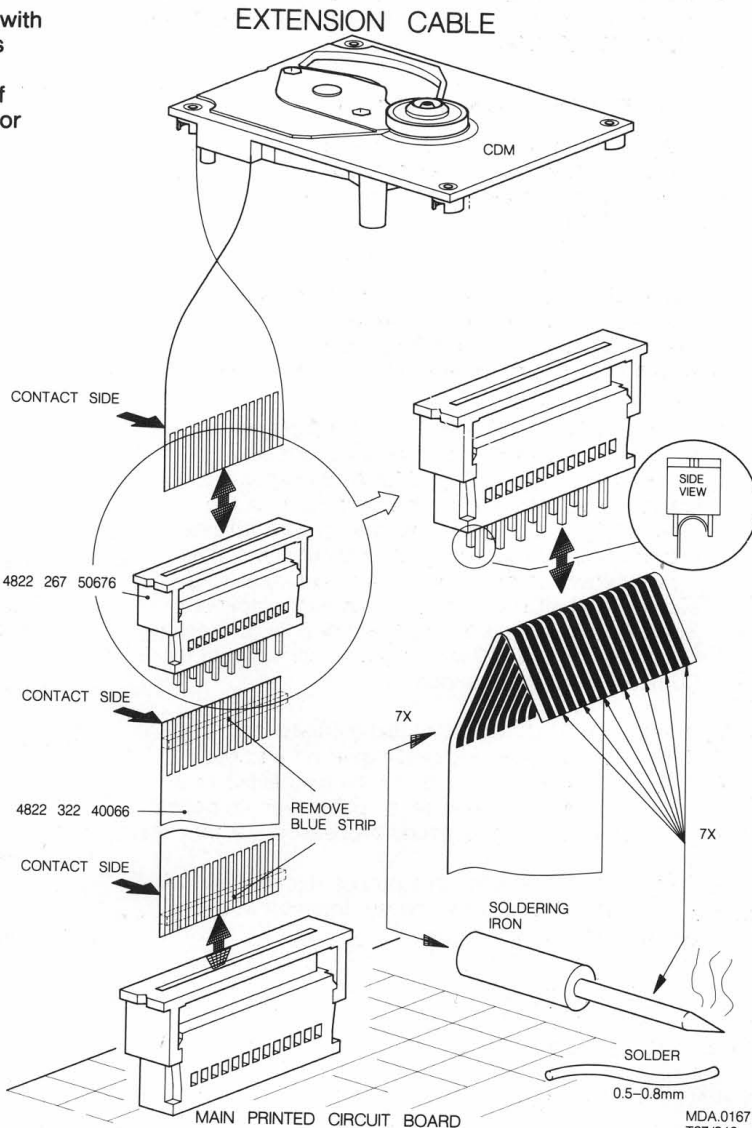

CABINET DISASSEMBLY HINTS

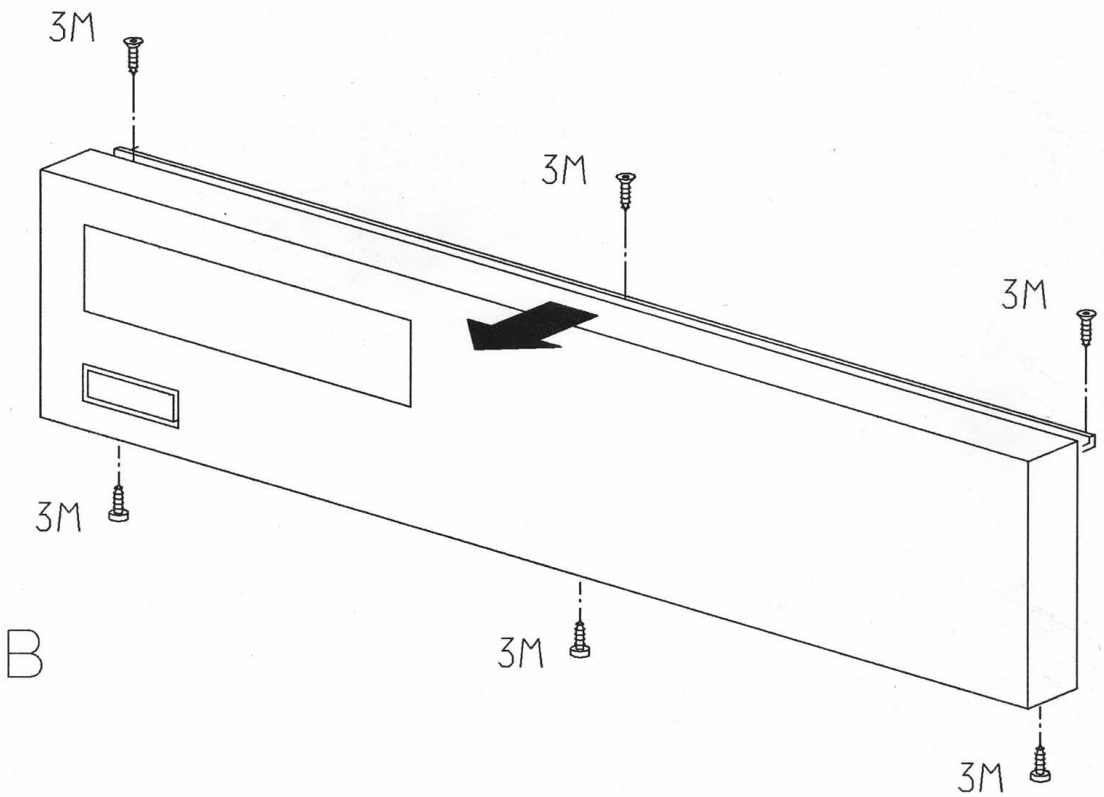
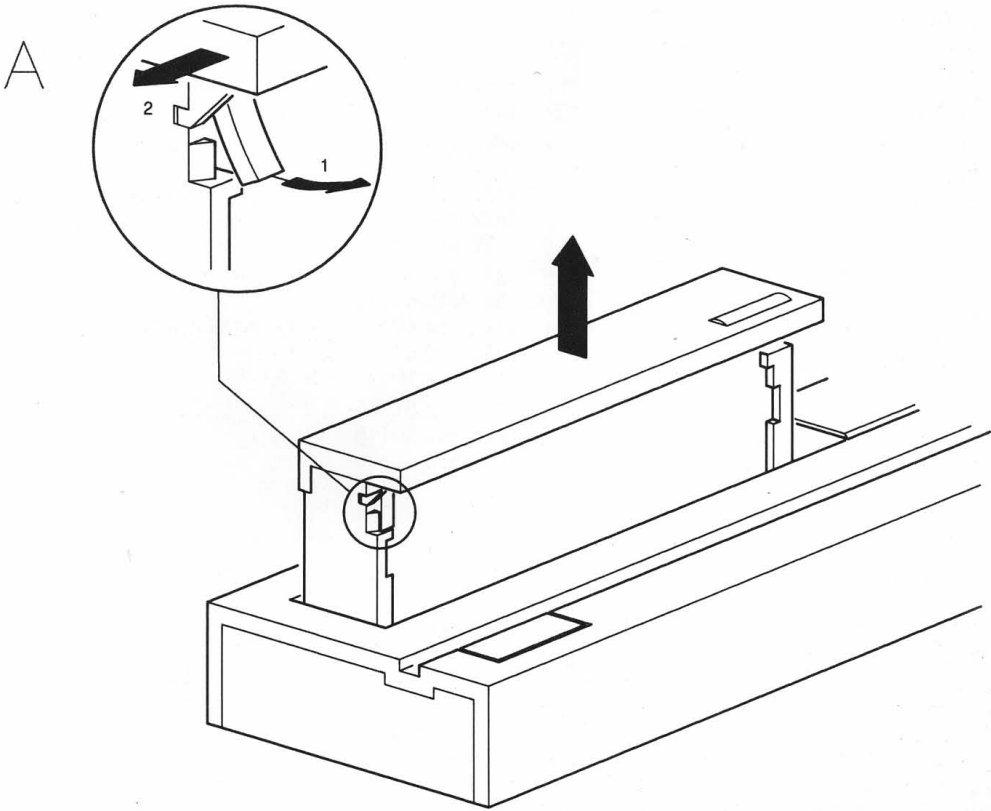

CONTROL+DISPLAY PANEL.

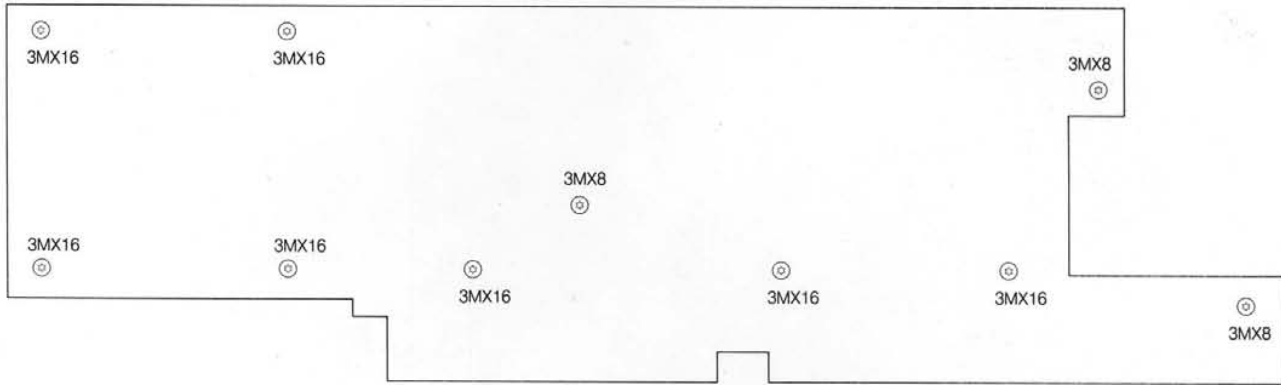

MDA.02140
916/T19

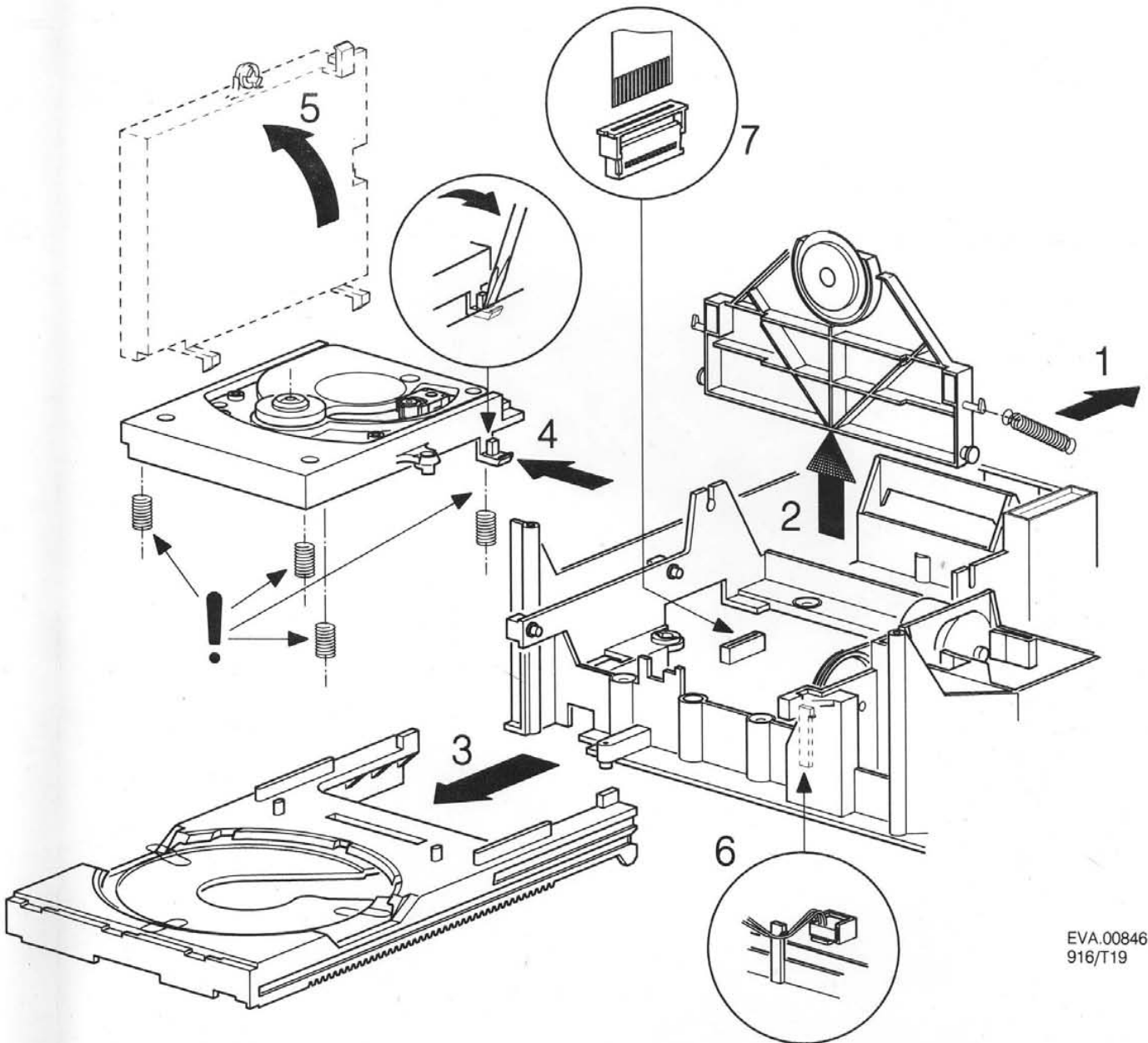

EVA.00846
916/T19

MECHANICAL

FOIL CONNECTION POSITION.

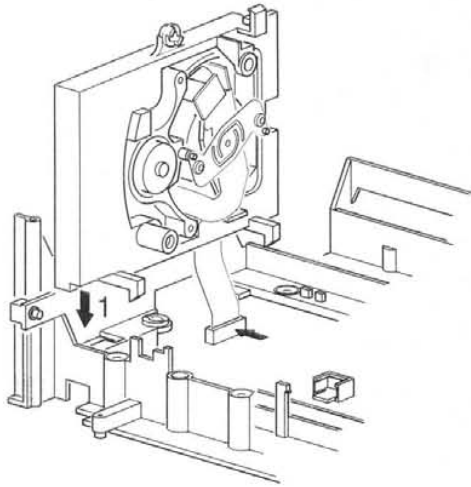

PLAY-SERVICE POSITION

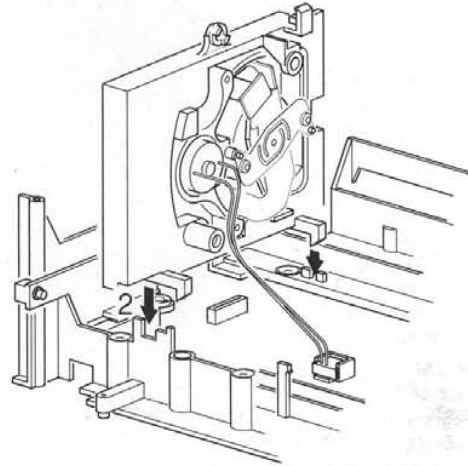

SERVICE POSITION PLAY

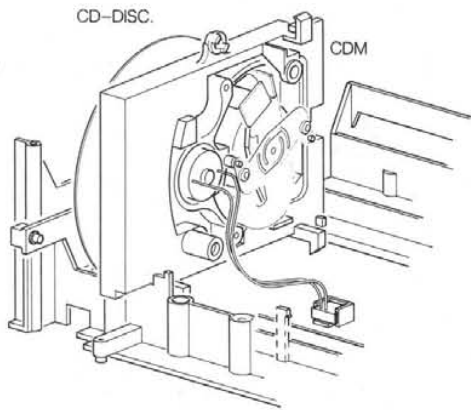

EVA.00849
916/T19

MEASURING AND ADJUSTMENT POSITION OF THE SET

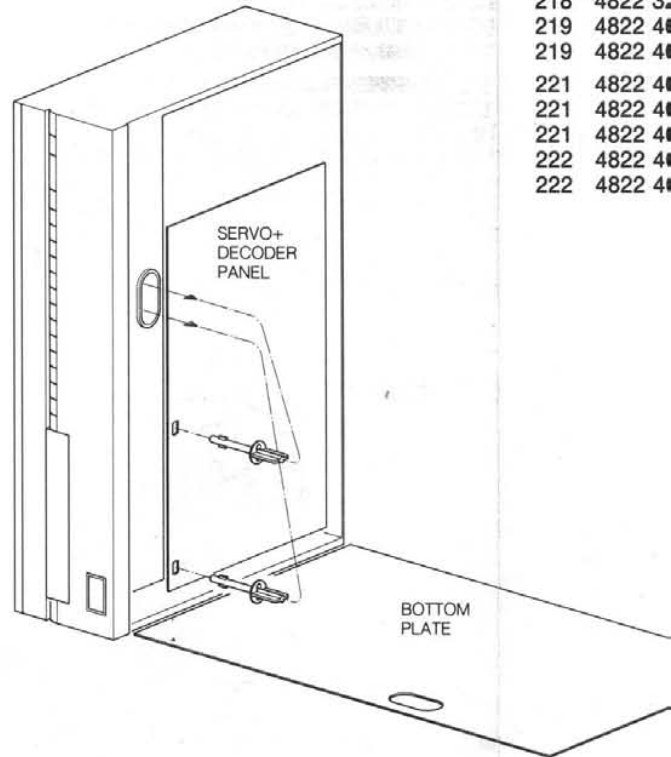

MDA.02138
916/T19

200	4822 21
200	4822 21
201	4822 45
201	4822 45
202	4822 44
202	4822 44
202	4822 44
202	4822 44
203	4822 45
203	4822 45
204	4822 46
204	4822 46
204	4822 46
205	4822 47
205	4822 47
206	4822 46
206	4822 46
206	4822 46
207	4822 44
207	4822 46
208	4822 32
209	4822 32
210	4822 49
211	4822 32
211	4822 32
212	4822 46
212	4822 46
213	4822 40
213	4822 40
214	4822 45
216	4822 40
217	4822 44
218	4822 32
219	4822 44
219	4822 44
221	4822 44
221	4822 44
221	4822 44
222	4822 44
222	4822 44

MECHANICAL PARTS

200	4822 218 10273	only for /01/02/04/05	223	4822 460 20657	only for /02G/04G
200	4822 218 10297	only for /06	223	4822 460 20766	only for /04B
201	4822 459 10887	only for /06	225	4822 321 22603	
201	4822 459 10747	only for /01/02/04	227	4822 410 50169	
202	4822 444 40321	FRONT ASSY only for /01B/02B/05B	227	4822 410 50169	
202	4822 444 40322	FRONT ASSY only for /02G/04G	227	4822 410 50169	
202	4822 444 40308	FRONT ASSY only for /04B	227	4822 410 50169	
202	4822 444 40328	FRONT ASSY only for /06B	228	4822 410 60202	only for /01B/02B/05B
203	4822 450 61444	WINDOW only for /06B	228	4822 410 60273	only for /02G/04G
203	4822 450 61358	WINDOW only for /01/02/04	228	4822 410 60115	only for /04B
204	4822 460 20769	ORN. PROFILE only for /04B	228	4822 410 60305	only for /06B
204	4822 460 20772	only for /01B/02B/05B/06B	229	4822 410 60118	
204	4822 460 20776	ORN. PROFILE only for /02G/04G	231	4822 410 60116	only for /01/02/04/05
205	4822 411 20337	VOLUME KNOB only for /02G/04G	231	4822 410 60303	only for /06
205	4822 410 60119	only for /01B/02B/04B/06B	232	4822 505 10571	M12 X 1
206	4822 460 20771	only for /01B/02B/05B/06B	233	4822 532 51756	
206	4822 460 20768	only for /04B	234	4822 358 10115	
206	4822 460 20775	only for /02G/04G	235	4822 530 80503	
207	4822 444 40323	only for /02G/04G	236	4822 325 50176	
207	4822 460 20764	only for /04B	237	4822 466 92251	
208	4822 321 10457	CORD SET only for /01/02	238	4822 528 90638	
209	4822 321 10522	CORD SET only for /05	239	4822 492 52094	
210	4822 492 61974		241	4822 402 61252	
211	4822 321 10445	CORD SET only for /06	242	4822 402 50276	
211	4822 321 10492	CORD SET only for /04	243	4822 323 20182	
212	4822 460 20774	only for /02G/04G	244	4822 276 30404	only for /01B/02B/05B
212	4822 460 20767	only for /04B	244	4822 410 60274	only for /02G/04G
213	4822 402 61297	POWER ROD only for /02G/04G	244	4822 276 30403	only for /04B
213	4822 402 61255	only for /01B/02B/04B/06B	244	4822 410 60304	only for /06B
214	4822 450 61362		246	4822 444 60568	
216	4822 402 50277		247	4822 466 92257	
217	4822 444 50603		248	4822 402 61207	
218	4822 325 50177		249	4822 520 40177	
219	4822 464 50773	only for /01B/02B/05B/06B	251	4822 691 30209	CDM-4 complete
219	4822 464 50764	only for /02G/04B/04G	252	4822 402 61253	
221	4822 402 61266	only for /01B/02B/05B	253	4822 528 81329	
221	4822 402 61254	only for /02G/04B/04G	254	4822 492 51902	
221	4822 402 61303	only for /06B	256	4822 466 61587	
222	4822 460 20773	only for /02G/04G	257	4822 492 51935	
222	4822 460 20763	only for /04B	258	4822 256 30274	FUSE HOLDER
			259	4822 492 32883	
			261	4822 528 90639	
			262	4822 361 20998	
			263	4822 402 61196	
			264	4822 535 92907	

CAUTION
INVISIBLE LASER RADIATION WHEN
OPEN DO NOT STARE INTO BEAM
3504 108 25947

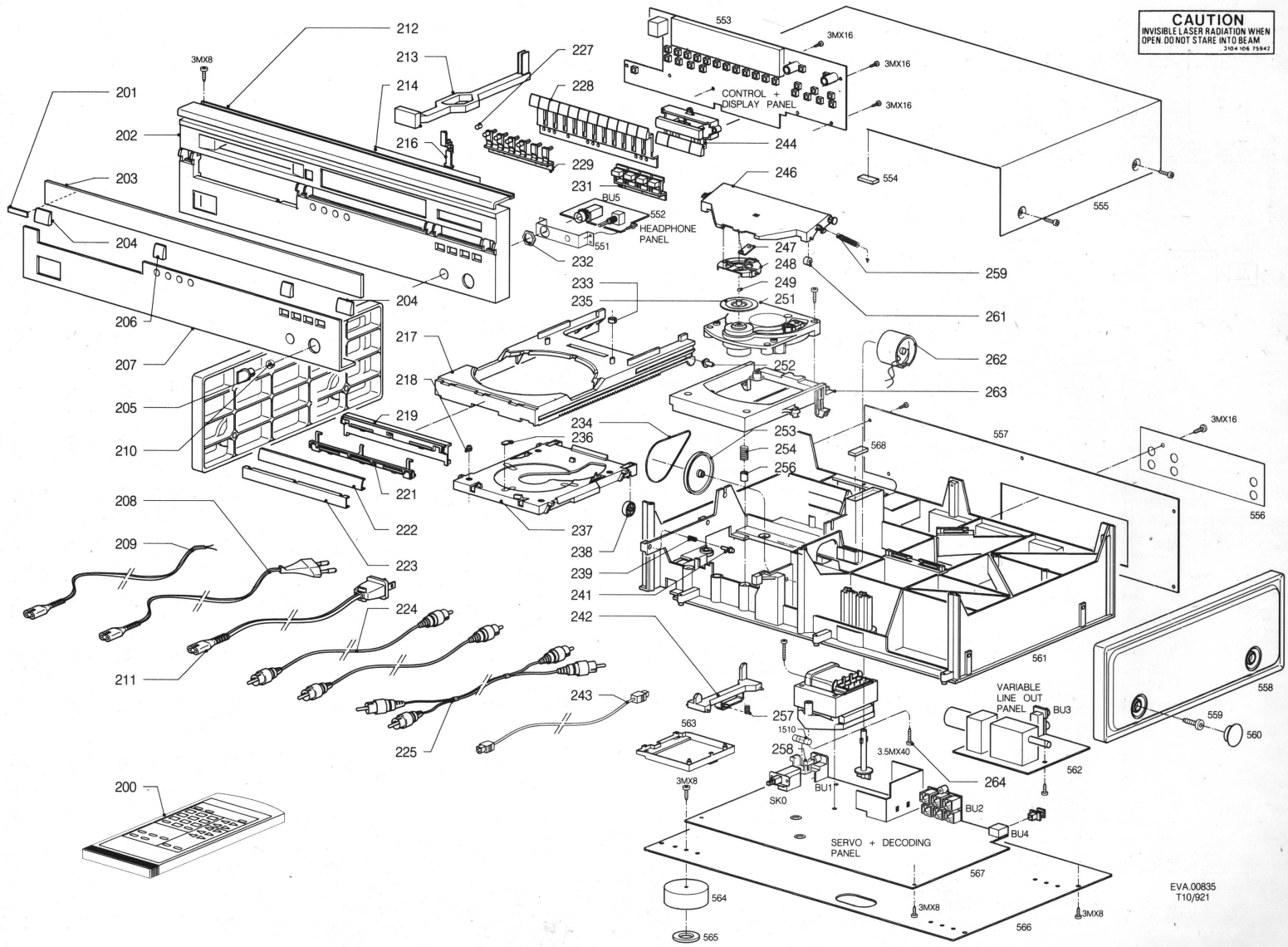

EVA 00835
T10/921

MEASUREMENTS AND ADJUSTMENTS

TROUBLE SHOOTING (FAULT FINDING TREE)

START-UP PROCEDURE

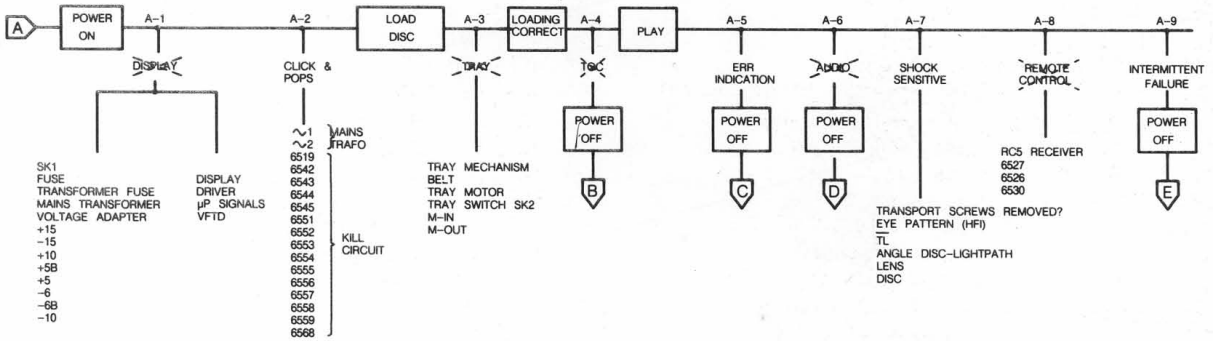

Follow the path of the faultfinding tree beginning at the top left. Perform the actions you come across in the various blocks. Look at the various side branches to find out if the information you see there applies to your problem. If, for instance, you find the indication **Display**, this means that no picture appears on the display.

If you establish this fault, follow the branch and perform the recommended actions. Check the signals mentioned. In a number of branches further reference is made to measurements you could carry out. These measurements are explained in several tables further on in this manual.

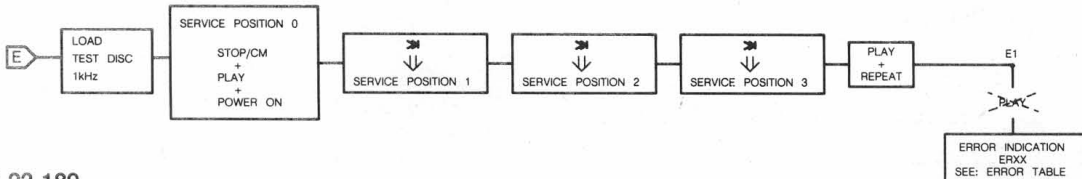
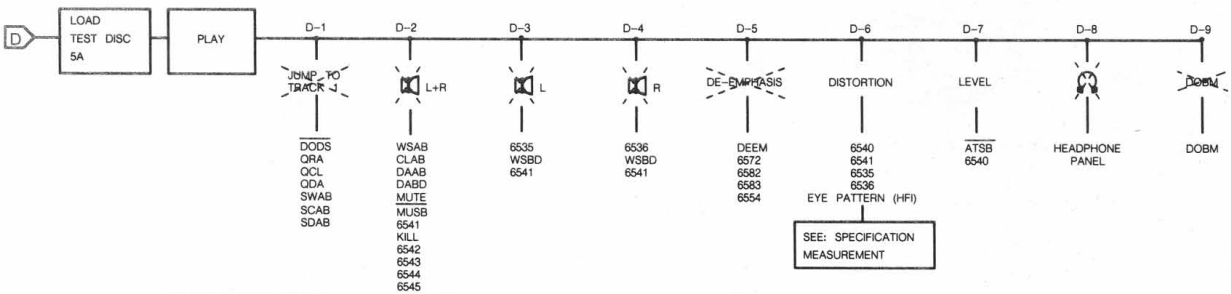
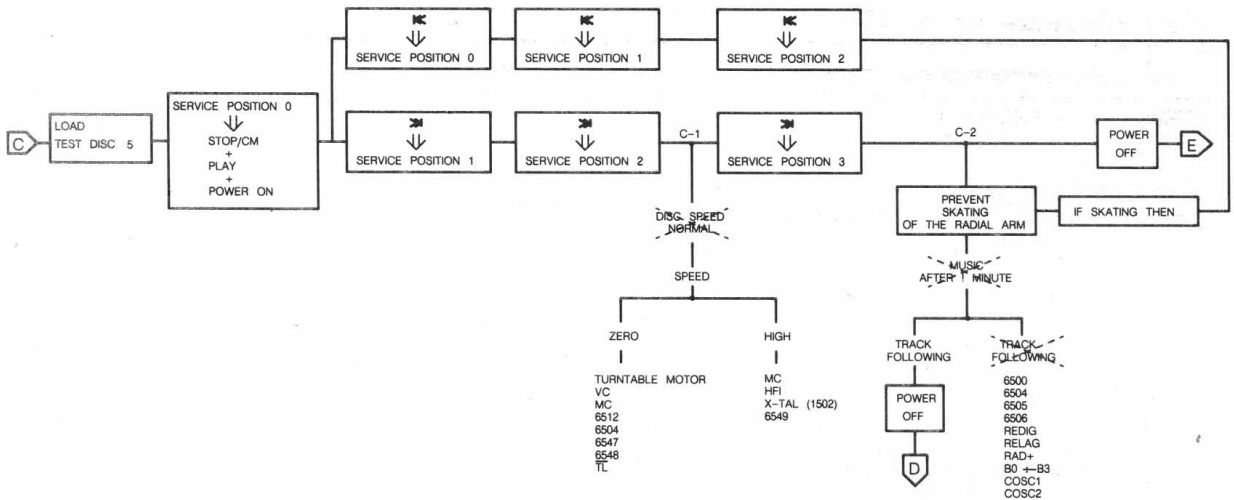
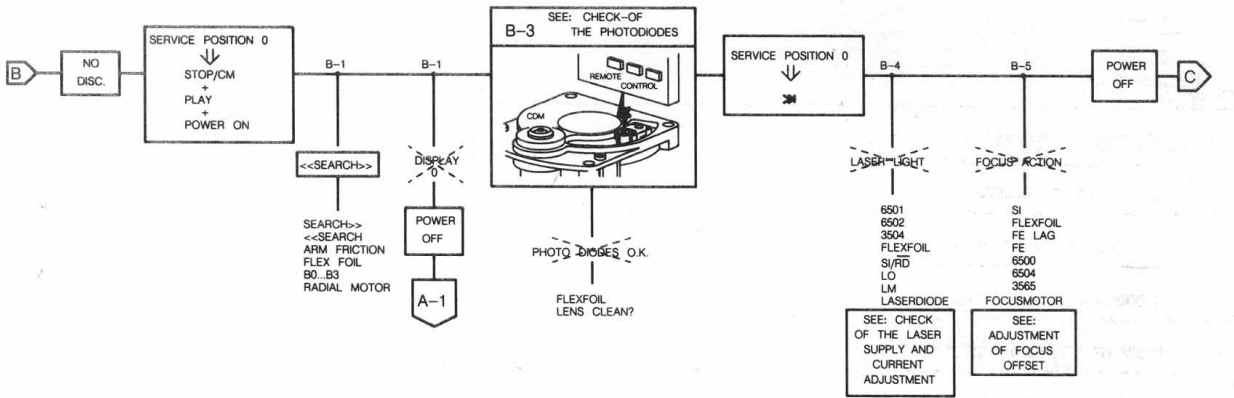

A-1 μ P - SIGNALS

Signal	Mode				Remarks
Reset	Power on	100		Pulse "high"	
X-TAL	Stand-by	101		4 MHz	
TRAY IN/OUT	2,5 Vdc when tray is inside	83		2,5 Vdc	"low" when tray is opening
				2,5 Vdc	"high" when tray is closing
$\overline{\text{ATSB}}$	DISC, SEARCH	89		"low"	
$\overline{\text{MUTE}}$	Play	67		"high"	pulses low in position pause
$\overline{\text{BWS}}$	8 cm disc	17		"high"	only when a 8 cm disc has been used.

B-2 B0, B1, B2, B3 SIGNALS

T-22387A

Signal	Mode				Remarks
B0	Service position 0 or 1; search \gg	36		"low"	
	Service position 0 or 1; search \ll	36		"low"	
B1	Service position 0 or 1; search \gg	34		"high"	
	Service position 0 or 1; search \ll	34		"high"	
B2	Service position 0 or 1; search \gg	33		"low"	
	Service position 0 or 1; search \ll	33		"high"	
B3	Service position 0 or 1; search \gg	32		"high"	
	Service position 0 or 1; search \ll	32		"high"	

B-3 CHECK OF THE PHOTODIODES

T-22387B

Step	Signal	Mode				Remarks
1	-	power on		-	-	See drawing 38314A12 Signal depends on Distance lens \leftrightarrow IR LED of remote control

B-4 CHECK OF LASER SUPPLY

T-22387C

The laser, the lasersupply plus the monitor diode form a feedback system.

A defect in the lasersupply may result in the destruction of the laser. If, in that case, the laser is replaced, (= complete C.D.M.-unit) the new laser will also become defective. However, it is impossible to check and repair a feedback system if a link is missing. For this reason the laser supply can be checked with the replacement circuit for laser assembly.

Step	Signal	Mode				Remarks
1	LO	serv. pos. 2		-	$1.8 < V < 2.3$	PRS05539
	LM	SK		-	$170 < \text{mV} < 220$	
2	LO	serv. pos. 2		-	$1.8 < V < 2.3$	PRS05540
	LM	SK		-	$170 < \text{mV} < 220$	
3	LO	Power on		-	$0V \pm 0.2V$	No light

T-22387D

B-4 LASER CURRENT ADJUSTMENT (see drawing MDA02138 measuring and adjustment position)

Step	Signal	Mode					Remarks
1	-	Power off		R3520	1kΩ	-	Pre-adjustment Ohmic value
2	Eye-pattern HFI	Power on Test disc 5 play		-	-	See drawing 37017B8	IF no signal see "start up procedure"
3	laser current = voltage across R3508	Test disc 5 play track 1		R3520	50 mV DC	-	use a high-ohmic voltmeter

T-22387E

B-5 ADJUSTMENT OF FOCUS-OFFSET (see drawing MDA02138 measuring and adjustment position)

Step	Signal	Mode					Remarks
1	-	Power on	-	R3568	-	-	adjust for optical mid-position of the focus motor
2	FE LAG	Play Test disc 5 Track 1	27	R3568	400mV ± 40 mV DC	-	fine adjustment

T-22387F

B-5 FOCUS ACTION

Signal	Mode				Remarks
SI/RD	Service position 1 when repeating focus start up	21			See drawing MDA.01403
FE	Service position 1, no disc	26			See drawing MDA.01413
FE-LAG	Test disc 5A, play	27			See adjustment of focus-offset

T-22387G

C-1 HIGH SPEED DISC ROTATION

Signal	Mode				Remarks
TL	Test disc 5, play or service position 2	13		Pulses "low"	TL indicates that the track has been found
HFI	Test disc 5, play or service position 2	65			See drawing: 37017B8
X-tal	Test disc 5A, play or service position 2	70		11.28 MHz	
MC	Test disc 5, play or service position 2	81			See drawing: 38849A12
		12			

T-22387H

C-2 TRACK FOLLOWING

Signal	Mode				Remarks
RE dig	Test disc 5, play or service position 3	37			
RE lag	Test disc 5, play or service position 3	41	≈ 2.5 Vdc		
C osc1	Test disc 5, play or service position 3	30		≈ 650 Hz	
C osc2	Test disc 5, play or service position 3	31		≈ 650 Hz	
RAD+	Test disc 5A, service position 1	40			Arm inside: 1V Arm inside: -1V
RE lead	Position stand-by	35		≈ 650 Hz	

T-22387I

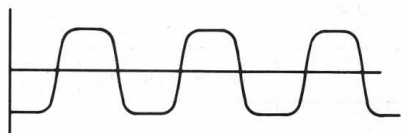

38 314 A12

HF-SIGNAL

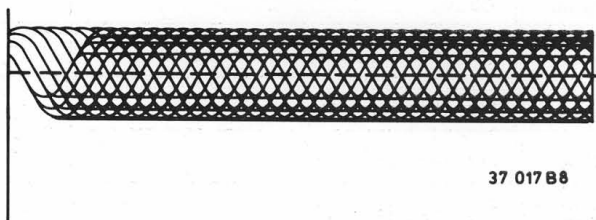

37 017 B8

MC-SIGNAL



POSITION: STAND BY.



POSITION: PLAY (BEGINNING)



POSITION: PLAY (NORMAL)

38 849 A12

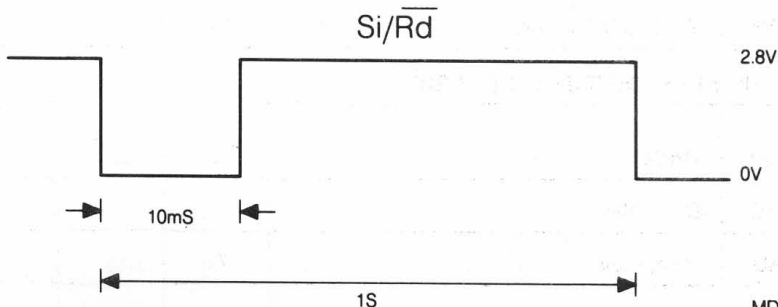

2.8V

0V

10mS

1S

MDA.01403
T33/821

FE-SIGNAL

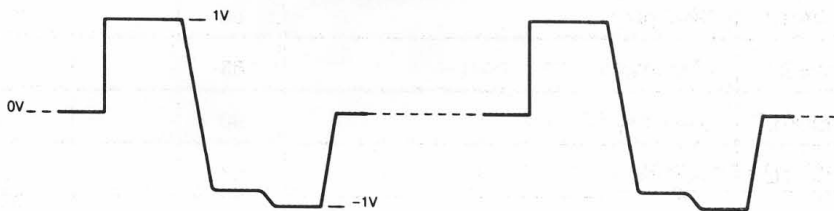

1V

0V

-1V

MDA.01413
T33/823

DOSD-SIGNAL

POSITION PLAYER	POWER ON	SERVICE POSITION 3	PLAY	SEARCH, PAUSE
DOSD SIGNAL	LOW	HIGH	HIGH	

MDA.01143
T12 -651

REPLACEMENT CIRCUIT FOR LASER ASSEMBLY

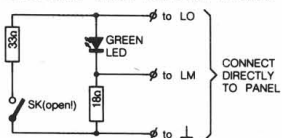

THE LED EMITS LITTLE LIGHT
LED GREEN e.g. COY94 5322 130 32182

PRS.05539
T28/845

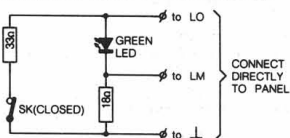

REPLACEMENT CIRCUIT FOR LASER ASSEMBLY



The feedback system sees to it that the same amount of current flows through the LED. When SK is open and when SK is closed the LED emits little light.



PRS.05540
T28/845

D1 JUMP TO TRACK 1

Signal	Mode				Remarks
DODS	Test disc 5A search >> or search <<	19			See drawing MDA.01143
QRA	Test disc 5A, play	75			} See drawing MDA.00453
QDA	Test disc 5A, play	77			
QCL	Test disc 5A, play	76			
SWAB/SSM	Test disc 5A, play	78			See drawing MDA.00239
SCAB	Test disc 5A, play	79			See drawing MDA.00239
SDAB	Test disc 5A, play	80			See drawing MDA.00239

T-22387J

D-2 NO AUDIO OUTPUT LEFT+RIGHT

Signal	Mode				Remarks
WSAB	Disc, play	71			} See drawing 38847C12
CLAB	Disc, play	72			
DAAB	Disc, play	73		activity	
EFAB	Testdisc 5A	74		pulses "high"	When the disc is slowly braked by hand
CLBD	Disc, play	87			} See drawing 38848C12
DABD	Disc, play	86		activity	
WSBD	Disc, play	85			
MUSB	Disc, play	90		"high"	Pause, next, prev, stop: "low"
MUTE	Disc, play	67		"high"	Pulses low during pause
AM	Disc, play	67		"high"	AM = additional mute

T-22387K

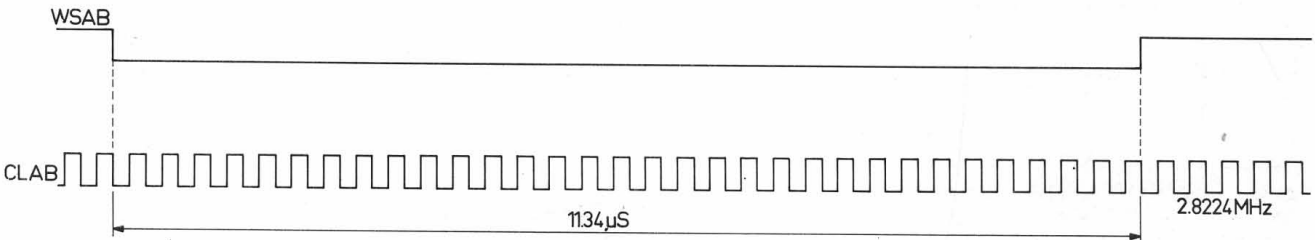

38 847 C12

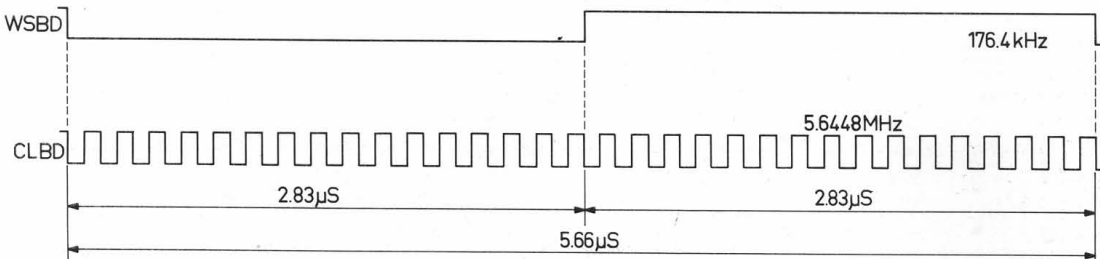

38 848 C12

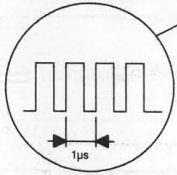
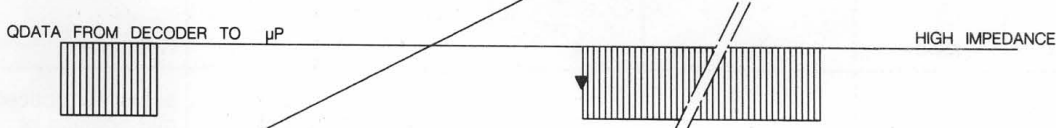
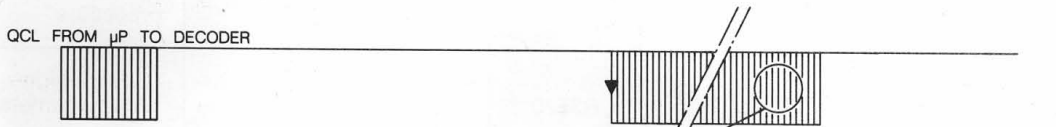
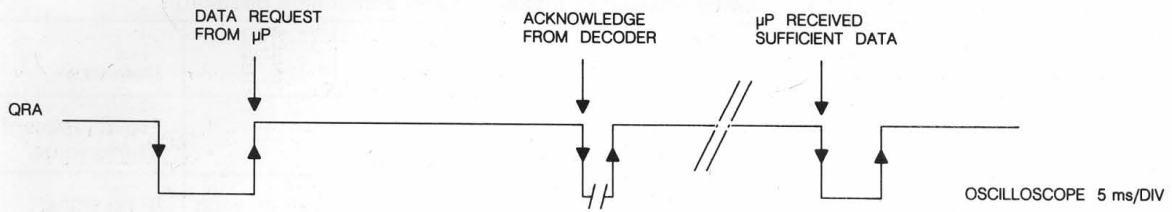

MDA.00453
T27/840

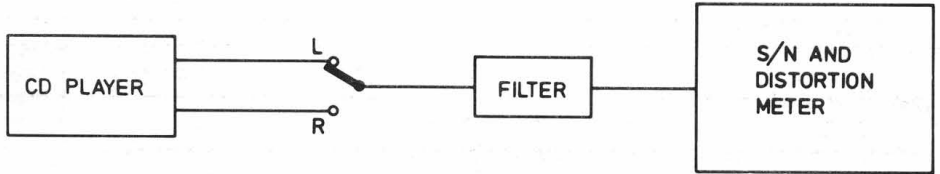

e.g. SOUND TECHNOLOGY
ST 1700B

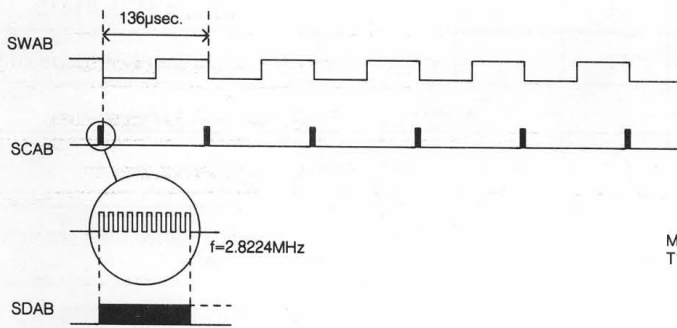

30 459 A12

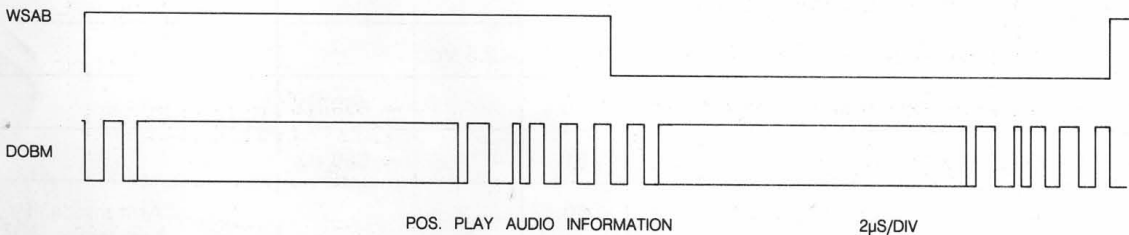
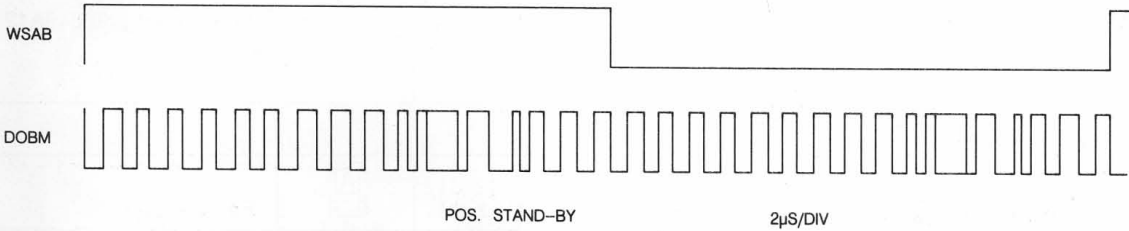

MDA.00239
T12/638





D-5 DEEM CIRCUIT

Signal	Mode				Remarks
DEEM	Test disc 5A: track 14 PLAY track 15 PLAY	84		"low" "high"	See testpoint 92 and 91 on DEEM circuit
Testpoint 92	Test disc 5A track 14	92		LF signal	
Testpoint 92	Test disc 5A track 15	92		No signal	
Testpoint 91	Test disc 5A track 14	91		LF signal	
Testpoint 91	Test disc 5A track 15	91		No signal	

T-22387L



D-6 SPECIFICATIONS MEASUREMENT

Signal	Mode				Remarks
BU2-L	Test disc 3, play, total harmonic distortion	filter output	See technical data		See drawing 30459A12
BU2-R	Test disc 3, play, total harmonic distortion	filter output	See technical data		See drawing 30459A12
BU2-L	Test disc 3, play signal-to-noise ratio	filter output	See technical data		See drawing 30459A12
BU2-R	Test disc 3, play signal-to-noise ratio	filter output	See technical data		See drawing 30459A12

T-22387M

Filter = 13th order filter 4822 395 30204

D-9 DOBM DIGITAL OUTPUT

Signal	Mode				Remarks
DOBM	Test disc 5A	88			See drawing MDA.00238

T-22387N

ERROR TABLE

System errors

Indication	Cause	Check
Er 02	No TL pulse at start-up	} Si, Sc, RD, Photodiode signal processor TL, HFI, CD disc present?
Er 03	No lead-in track found	
Er 06	No TL pulse within 0.5 sec. during track jumping	CD disc, radial arm position, REdig, Radial error processor
Er 07	Subcoding error during PLAY	RE-lag circuit, TL, REdig
Er 08	TOC error	HFI CD disc, turntable motor control, radial arm position

Operating errors

- Er 30 "NEXT" key operated during the last track, with "REPEAT" turned off.
- Er 31 "PREVIOUS" key operated during the first track, with "REPEAT" turned off.
- Er 32 AB key operated in AMS mode.
- Er 33 The selected index number does not exist on this disc.
- Er 34 Programme survey requested; no programme present.
- Er 35 The programme memory is full.
- Er 36 The programmed track is not present on this CD disc.
- Er 37 The selected track is not present on this CD disc.
- Er 38 MEMO pressed during AMS while track not known.
MEMO pressed during EDIT while cassette time = 0 sec.
- Er 39 MEMO or CANCEL pressed while in play program.
- Er 40 MEMO pressed when already a delete program has been made.
- Er 41 CANCEL pressed when already a not deleted program has been made.
- Er 42 Selected track is not a program block.
- Er 43 FTS store error: memory full.
- Er 44 FTS store error: no program.
- Er 46 FTS play error: no FTS program in memory.
- Er 47 FTS selection error: upper bound of fts memory. (next).
- Er 49 FTS selection error: selection request while storing. (next/prev).
- Er 51 FTS selection error: selection request while storing. (review).
- Er 52 FTS selection clear error: clear request while storing.
- Er 54 FTS store error: no record id (toc) available.
- Er 56 AB key pressed when not in PLAY mode.
- Er 60 Fast forward/reverse bound.
- Er 63 No track possible to play in edit mode.
- Er 74 Relative time not found.
- Er 75 Binary search time out error.
- Er 76 Time search time out error.

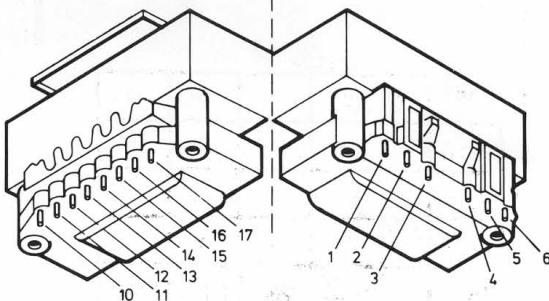
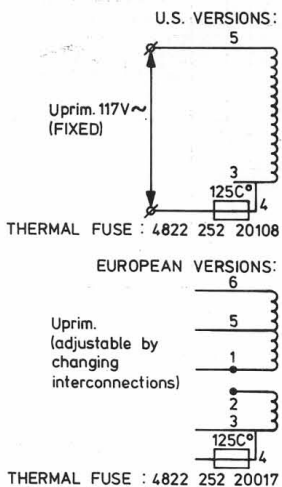

Uprim. (V) ~	Winding	Inter-connect
110	4-1	3-1/5-2
127	4-6	3-1/5-2
220	4-5	1-2
240	4-6	1-2

44 577 A11

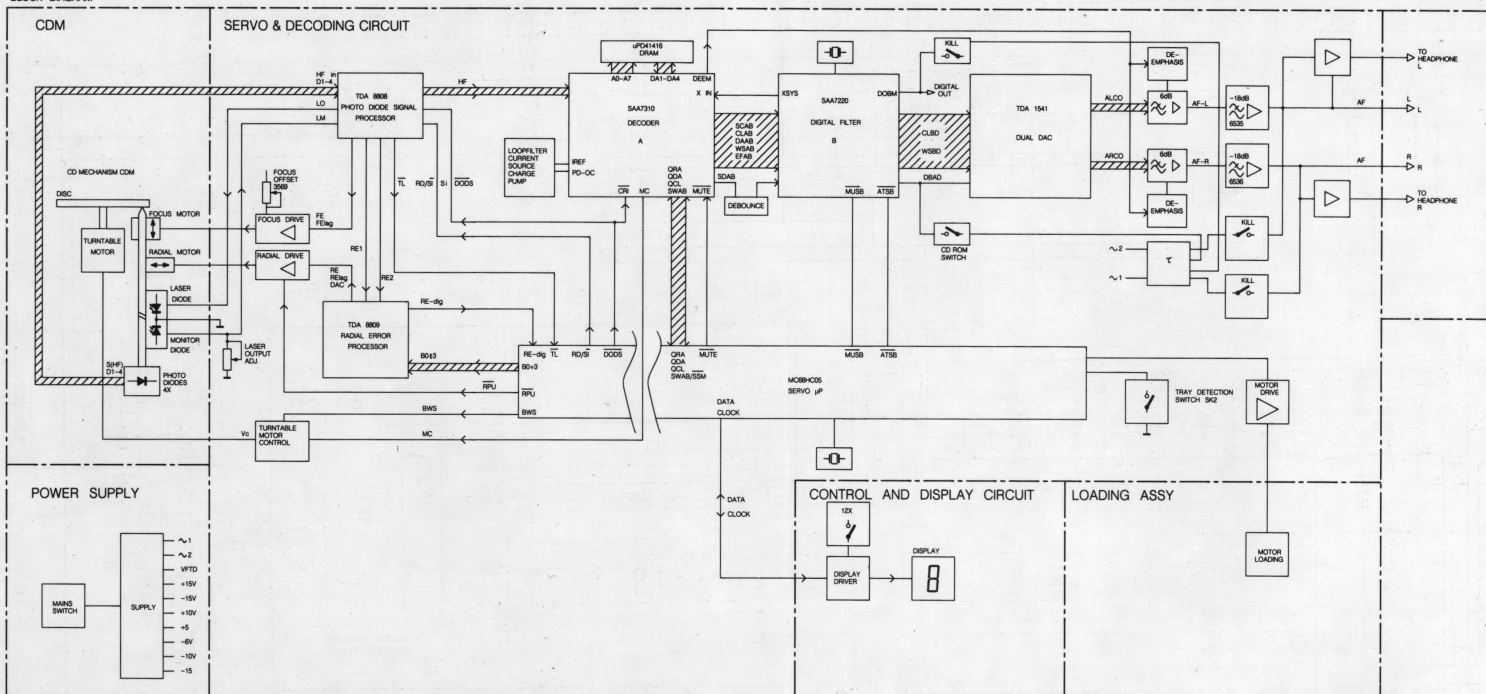

DECODING SIGNALS

ATSB	- Attenuation of Audio level in search position (Cueing)
CD ROM switch	- Digital Data information on disc signal
CEFM	- Clock Eight-to-Fourteen Modulator
CLAB	- Clock signal Decoder-A to Filter-B
CLBD	- Clock signal Filter-B to DAC
CREF	- Reference Current
CRI	- Counter Reset Inhibit
DAAB	- Data signal Decoder-A to Filter-B
DABD	- Data signal Filter-B to DAC
DEEM	- Deemphasis
DO5M	- Digital out signal
EFAB	- Error flag Decoder-A to Filter-B
MUTE	- Mute signal
MUSB	- Soft Mute signal
PD/OC	- Phase detector - oscillator control
QCL	- Q-channel Clock signal
QDA	- Q-channel Data signal
QRA	- Q-channel Request Acknowledge
SCAB	- Subcode clock Decoder-A to Filter-B
SDAB	- Subcode data Decoder-A to Filter-B
SWAB/SSM	- Subcode Word/Start-stop motor signal
WSAB	- Word select Decoder-A to Filter-B
WSBD	- Word select Filter-B to DAC
XIN	- Oscillator signal in Decoder-A
XSYS	- Oscillator signal out Filter-B

SERVO SIGNALS

AGC	- Automatic Gain Control
B0-B3	- Control bits for radial circuit
BEQ	- Equalizer reference current input
BGC	- DC and LF gain control reference input
BWS	- Band Width Switch 8/12 cm disc
Cosc1	- Capacitor wobble oscillator
Cosc2	- Capacitor wobble oscillator
DEC	- Decoupling input of inkrunt bypass
DET	- HF detector voltage input
DIV4	- Divide by 4 input
DODS	- Drop out detector suppression
D1+4	- Photodiode currents
FE	- Focus error signal
FE lag	- Focus error signal for LAG network
HF	- HF output for DEMOD
HFD	- HF detector output for DEMOD
HF-in	- HF current input to HF amplifier
HF-out	- HF amplifier and equalizer voltage output
LM	- Laser monitor diode input
LO	- Laser amplifier current output
MC	- Motor control signal
offset IN	- Offset control output
offset OUT	- Offset control output
PLLH	- PLL on hold output

RADout

RE	- Output of RE2-RE1 input
RE	- Radial error signal (Amplifier RE _E -RTE _E currents)
Rosc	- Resistor wobble oscillator
Rwob	- Wobble generator input
RE1	- Radial error signal 1 (summation of amplified currents D ₃ and D ₄)
RE2	- Radial error signal 2 (summation of amplified currents D ₁ and D ₂)
RE dig	- Radial error digital
RE lag	- Radial error signal for LAG network
Sc	- Starting up capacitor input
SI/RD	- On/off control for laser supply and focus circuit. Ready signal, Starting up procedure successful.
TCMP	- Turntable control motor pulse
TL	- Track loss output signal
TTM-	- Control voltage for turntable motor
TTM+	- Control voltage for turntable motor
Vext-	- Supply connection
Vext+	- Supply connection

1001 J 1	2503 E 4	2509 F 8	2520 J 3	2534 C17	2545 E20	2545 F20	2562 M3	2572 M7	2623 A 8	3506 E 6	3520 L 3	3530 D14	3538 D 9	3543 E10	3597 H20	3564 M3	3569 M1	3579 M7	3585 L15	3591 N1	3625 A18	3846 D 7	3822 D 7	3841 D17	6504 D18	6512 N14	6548 N20
1002 K 1	2504 F 4	2510 J 8	2521 J 3	2535 I15	2547 I 9	2546 K12	2563 L13	2574 N14	2624 A10	3507 E 6	3521 L 3	3531 D15	3539 F11	3545 K12	3560 L10	3561 L11	3574 M13	3580 D14	3586 D13	3592 A15	3626 A17	3807 D18	3822 B 3	3847 L13	6504 K11	6518 N16	
1003 J 1	2506 E 5	2511 F 8	2520 D15	2536 I15	2542 L12	2550 H19	2565 J11	2620 A 9	3501 F 3	3508 E 6	3522 J 3	3533 D19	3540 F20	3546 L12	3561 K10	3566 L11	3575 O15	3581 M16	3587 O13	3622 B15	3627 A 8	3813 N12	3826 I10	3801 K10	6504 M16	6517 N14	
1004 A 8	2507 E 6	2511 M11	2531 D16	2537 J13	2544 K12	2560 K10	2570 M18	2621 A 9	3502 F 3	3509 L 9	3523 J 2	3534 D17	3541 F19	3552 M10	3561 L11	3576 M10	3582 M7	3588 N14	3623 B15	3628 A 8	3815 D 8	3823 B 9	3829 B 9	6502 J 3	6506 F18	6518 M14	
2501 F 2	2508 G 5	2514 E 6	2532 I16	2538 D14	2544 L12	2561 M9	2571 N15	2622 A 7	3505 E 7	3510 I10	3524 J 3	3535 D13	3542 F20	3555 D19	3563 M13	3568 M12	3578 N18	3584 M15	3589 M14	3624 B17	3629 A 9	3816 A17	3840 D17	6503 D11	6508 E19	6547 M20	

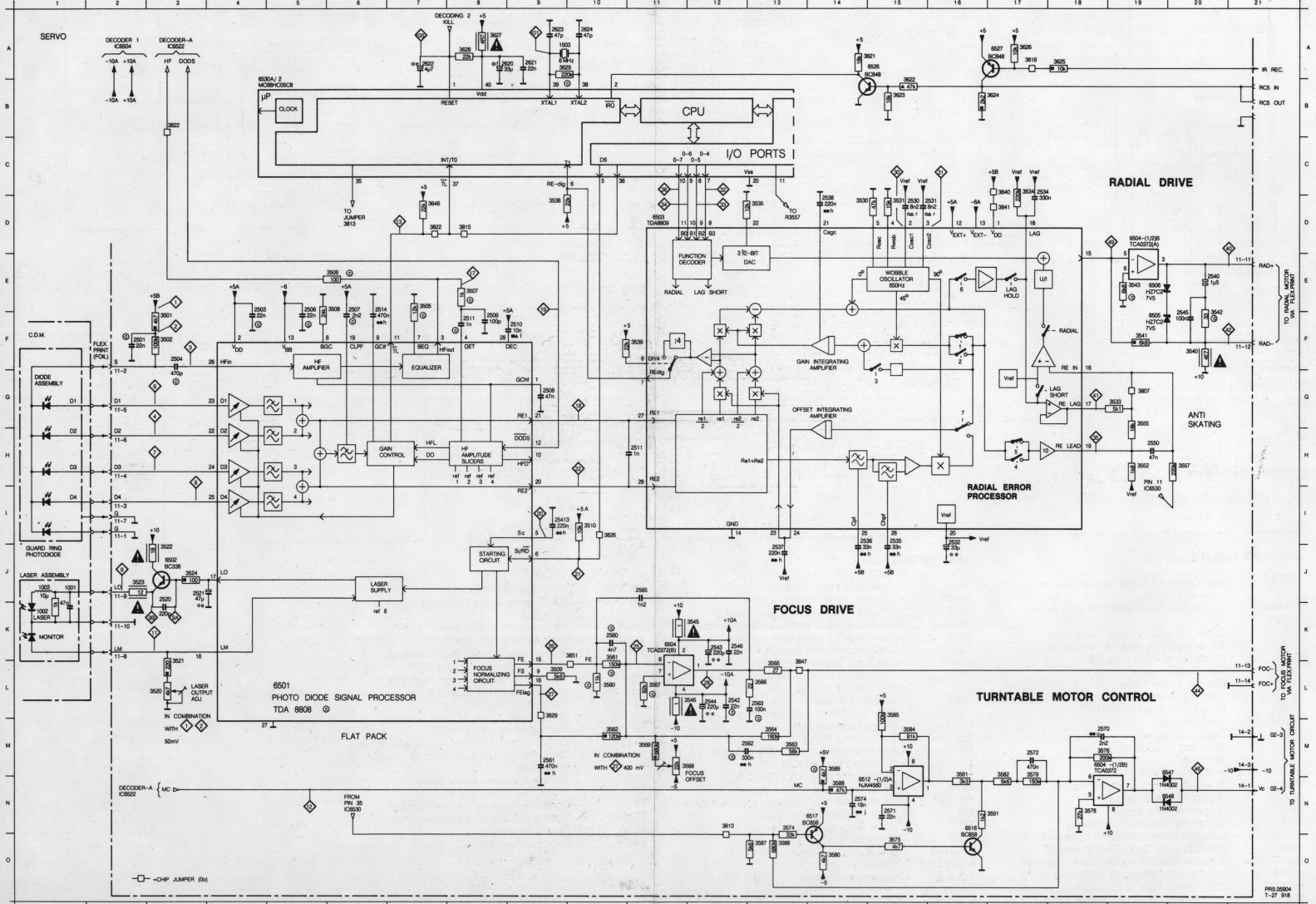

SERVO + DECODER PANEL

2	89	158	F5	182	F2	280	C4	238	3A	254	3A	2520	F2	2569	E2	2638	F5	2607	F7	2891	B8	3591	D1	3513	F1	3584	E5	3624	C5	3607	E5	3693	E5	3739	B8	3884	E8	3828	B8	3853	B5	3828	F2	3537	C5	3553	B5	3509	B5	3509	B5
3	4	7	158	B0	188	C0	287	C0	271	B1	255	B1	2521	F1	2584	B1	2651	E8	2668	B0	2822	B8	3582	F2	3545	F2	3585	E5	3625	C5	3658	F7	3684	E5	3727	B8	3868	F3	3820	E1	3854	B8	3582	F2	3539	C5	3548	B8	3509	B5	
6	35	108	F7	184	C0	288	C4	282	3B	287	B1	2522	C5	2585	E2	2632	F7	2609	C7	2863	E8	3583	D9	3540	D1	3580	E4	3620	C5	3659	G0	3686	E5	3729	B8	3869	D3	3820	D4	3855	B8	3820	F2	3541	B8	3509	B5				
7	3	6	181	B7	195	D0	289	E0	233	2A	258	C1	2528	C5	2590	B3	2653	E8	2670	C8	2866	D9	3584	D4	3552	D3	3589	E5	3627	C8	3657	F5	3740	B8	3888	B5	3832	C5	3857	D5	3890	E1	3542	B8	3509	B5					
8	65	162	F8	186	B5	218	E3	234	2A	1880	E0	2524	B5	2567	F3	2634	D0	2611	C7	2860	D9	3585	D2	3555	D2	3588	E5	3628	D4	3660	B8	3702	B8	3744	D7	3818	B8	3834	D8	3859	E0	3511	C4	3544	B8	3509	B5				
9	F8	162	F5	187	F0	211	E7	235	2A	1581	A2	2528	C5	2569	B3	2635	D0	2612	B8	2867	D9	3586	D9	3557	D3	3590	D5	3624	B8	3657	C8	3703	B8	3745	C8	3811	C7	3835	F8	3859	A5	3811	C4	3545	B8	3509	B5				
11	E2	154	D0	188	D3	212	E7	236	B7	1182	F0	2526	C5	2570	F3	2636	D0	2613	B8	2868	D7	3587	D2	3568	D3	3581	A4	3630	D7	3660	B8	3702	B8	3744	D7	3818	B8	3834	D8	3859	E0	3511	C4	3544	B8	3509	B5				
12	B7	165	F8	188	D8	219	C1	237	3A	1583	B3	2528	C5	2572	F4	2638	F8	2614	C8	2869	D7	3588	D2	3561	E1	3594	B8	3630	D7	3660	B8	3702	B8	3744	D7	3818	B8	3834	D8	3859	E0	3511	C4	3544	B8	3509	B5				
14	F4	165	E4	190	F7	214	B7	238	3B	1518	B1	2538	D1	2574	E5	2639	B8	2615	C8	2780	B8	3589	D3	3562	E1	3595	B8	3630	D7	3660	B8	3702	B8	3744	D7	3818	B8	3834	D8	3859	E0	3511	C4	3544	B8	3509	B5				
15	B5	167	D0	191	E2	215	C1	239	3B	2580	B1	2531	D1	2580	B3	2640	A8	2616	C8	2782	C8	3590	E2	3564	D1	3584	E5	3630	E5	3672	C7	3700	B7	3759	A7	3814	E3	3838	F4	3864	C0	3515	C0	3548	F4	3577	C5				
16	A1	168	D3	192	C4	216	C3	240	E4	2581	E1	2532	C1	2580	B3	2640	A8	2616	C8	2782	C8	3590	E2	3564	D1	3584	E5	3630	E5	3672	C7	3700	B7	3759	A7	3814	E3	3838	F4	3864	C0	3515	C0	3548	F4	3577	C5				
17	A2	169	D3	193	B6	217	D7	241	C1	2582	D2	2534	D1	2582	E6	2642	A6	2618	B8	2784	A5	3521	D3	3565	E2	3586	D0	3630	F7	3642	C5	3675	B5	3718	E5	3770	E5	3817	D3	3842	C0	3867	C4	3516	A4	3581	A4				
18	B8	170	E4	194	E8	218	C8	242	E4	2583	E1	2535	C1	2581	D0	2641	G0	2619	E8	2784	A5	3522	E2	3566	E2	3587	B8	3630	F7	3642	C5	3675	B5	3718	E5	3770	E5	3817	D3	3842	C0	3867	C4	3516	A4	3581	A4				
20	B1	171	F7	195	C5	219	C0	243	B8	2585	D0	2536	D2	2587	E8	2644	E4	2620	E8	2785	A4	3523	E2	3567	E1	3589	F7	3642	C5	3675	B5	3718	E5	3770	E5	3817	D3	3842	C0	3867	C4	3516	A4	3581	A4						
23	D5	172	B4	195	E8	220	D4	244	B8	2587	E2	2537	D1	2588	E6	2645	F3	2621	E8	2786	B8	3524	F2	3568	C3	3591	C2	3560	D1	3581	D0	3645	B5	3670	E4	3720	E3	3762	C3	3803	C3	3828	F7	3517	B8	3509	B5				
26	E7	173	E3	197	F5	221	C4	245	B7	2590	D2	2538	D1	2590	D0	2646	F3	2622	E8	2787	B4	3525	C2	3569	D1	3582	B8	3630	F7	3642	C5	3675	B5	3718	E5	3770	E5	3817	D3	3842	C0	3867	C4	3516	A4	3581	A4				
188	F1	174	D5	198	E7	222	C3	246	F1	2591	F1	2539	C1	2591	C4	2647	F4	2623	E8	2788	B8	3526	C2	3570	F1	3583	C2	3562	D1	3582	B8	3630	F7	3642	C5	3675	B5	3718	E5	3770	E5	3817	D3	3842	C0	3867	C4	3516	A4	3581	A4
151	E7	175	B7	198	F8	223	E7	247	A4	2518	E2	2542	F2	2611	F7	2681	D8	2664	D0	2790	C4	3533	D2	3575	F3	3515	E5	3547	C4	3670	B8	3724	B3	3784	F5	3821	E8	3848	E3	3871	E6	3527	C5	3558	B5	3586	C4				
152	F0	176	F8	200	B4	224	B5	248	E1	2519	E2	2543	F1	2612	F7	2682	D8	2665	D0	2791	B8	3534	F2	3576	F3	3516	E5	3548	B8	3670	B8	3724	B3	3784	F5	3821	E8	3848	E3	3871	E6	3527	C5	3558	B5	3586	C4				
153	D0	177	F2	201	B8	225	D3	249	E2	2513	D2	2545	F2	2613	D0	2683	F3	2666	D0	2791	B8	3535	D2	3578	F3	3517	D5	3551	B8	3670	B8	3724	B3	3784	F5	3821	E8	3848	E3	3871	E6	3527	C5	3558	B5	3586	C4				
154	F6	178	B7	202	E5	225	C0	250	E1	2514	E4	2546	F3	2614	D0	2684	F3	2667	D0	2792	B8	3536	D2	3579	F4	3518	D5	3552	B8	3670	B8	3724	B3	3784	F5	3821	E8	3848	E3	3871	E6	3527	C5	3558	B5	3586	C4				
155	F8	178	E3	203	E2	227	E4	251	D9	2515	E2	2548	E1	2622	A4	2684	D4	2668	D0	2793	A4	3537	E1	3580	F3	3519	E5	3553	A8	3670	B8	3724	B3	3784	F5	3821	E8	3848	E3	3871	E6	3527	C5	3558	B5	3586	C4				
156	F8	180	B7	204	D9	228	3A	252	D8	2517	D9	2549	E1	2623	B5	2686	D8	2669	D0	2794	A8	3538	E1	3581	A4	3522	E5	3554	A8	3670	B8	3724	B3	3784	F5	3821	E8	3848	E3	3871	E6	3527	C5	3558	B5	3586	C4				
157	C0	181	F4	205	C4	229	C4	253	B1	2519	C4	2552	D1	2624	B5	2688	C0	2670	E5	2795	B8	3539	E4	3582	E4	3523	E4	3555	A8	3670	B8	3724	B3	3784	F5	3821	E8	3848	E3	3871	E6	3527	C5	3558	B5	3586	C4				

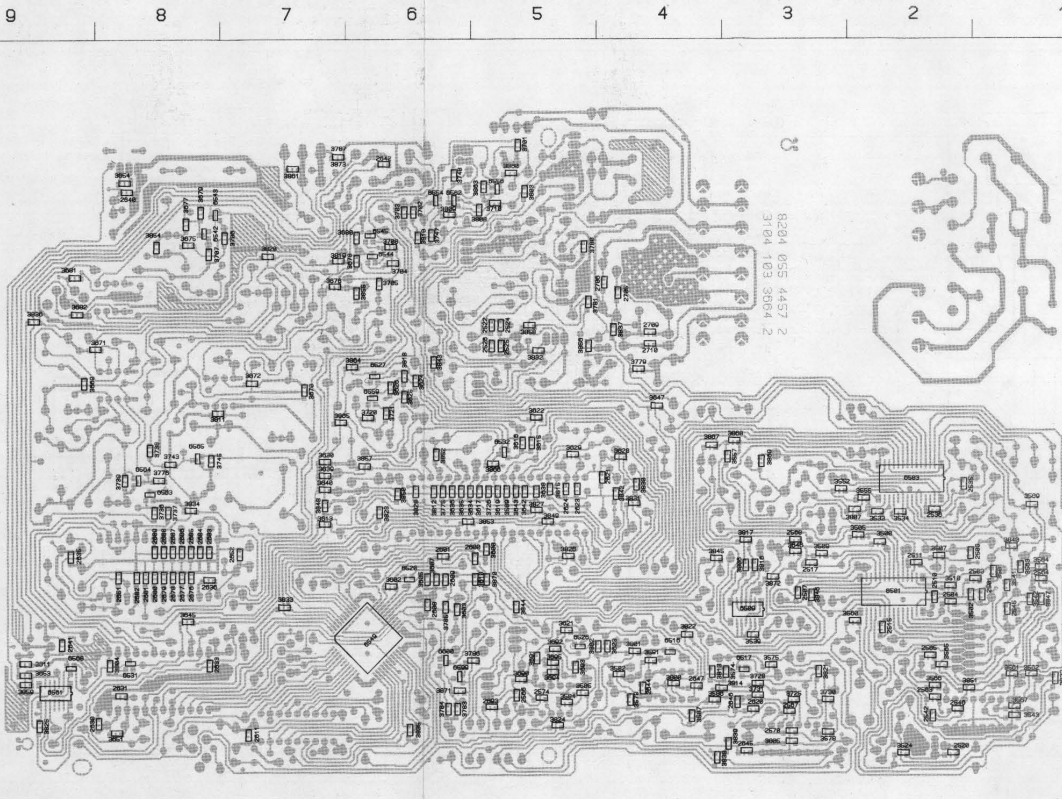

1000 H1 2603 G 2 2609 M 3 2620 B16 2633 N17 2641 I 20 2646 C19 3602 J 2 3610 I 1 3630 B10 3643 B 9 3653 K19 3659 I 20 3694 B 6 3722 A15 3729 C17 3785 J 2 3823 E 6 3835 M 4 3850 B14 3859 K19 6520 H 2 6531 F16 6561C F11 6575 A 7
 1522 N13 2624 J 2 2629 M 1 2630 N13 2638 O19 2642 I 21 2622 A 6 3605 H 3 3611 H02 3638 A11 3646 E15 3653 H02 3666 B 4 3686 B 6 3724 A16 3730 C18 3821 H19 3822 O12 3838 B18 3852 B13 3856 B13 6522 E 2 6540 G11 6568 H19 6576 B 7
 2600 F 2 2607 M 1 2611 N 8 2631 N14 2639 M02 2644 A10 3800 F 1 3807 H 1 3613 E 7 3639 A13 3650 N11 3654 M02 3669 B 4 3686 A 7 3725 A19 3731 C19 3821 C17 3827 C17 3839 B18 3853 B14 6557 L 6532 N 5 6561A H19 6569 K19 SK-2 B11
 2601 F 2 2609 M 2 2612 N 9 2632 H18 2640 M02 2645 C18 3622 F 2 3609 M 9 3619 B13 3646 A14 3651 M13 3656 M18 3693 B 6 3697 B 7 3728 C17 3735 C16 3822 C17 3828 C16 3849 B14 3857 A10 6512 A 5 6530B B 2 6561B H19 6571 A14

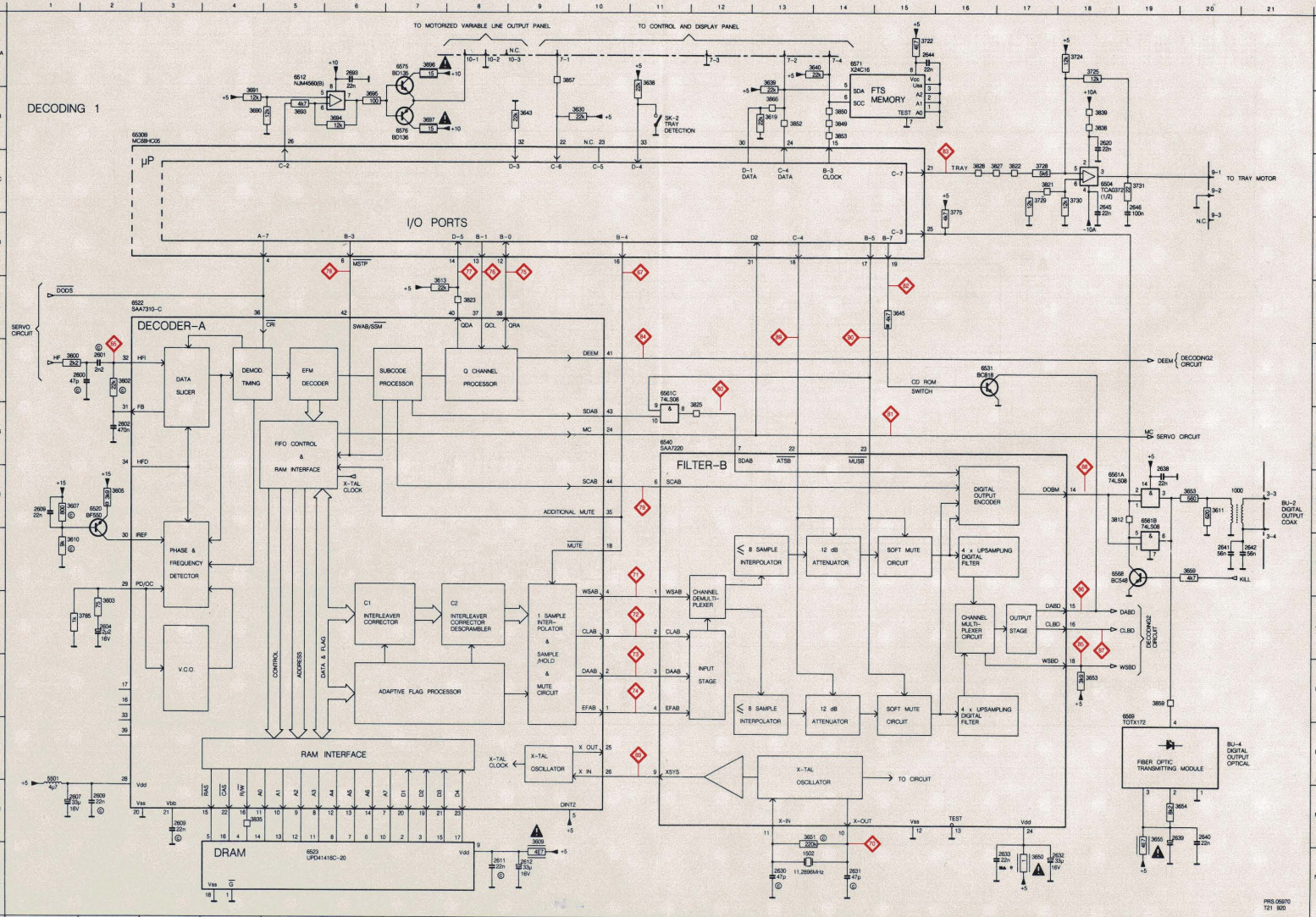

2634 D 4	2653 E 9	2667 D12	2671 D14	2677 I 6	2682 H 8	2687 B 7	2695 B16	3652 C 4	3666 D11	3671 H13	3676 D15	3681 G19	3705 E17	3710 G16	3738 I 9	3747 F16	3802 J 2	3808 F16	5502 I12	6526A C11	6544 D16	6553 G14	6558 F15	6564 J11
2635 D 4	2654 F 9	2668 H13	2673 D14	2678 I 7	2683 C 6	2688 C 7	2696 H12	3653 E 5	3667 D11	3672 D13	3677 H15	3700 F16	3709 H16	3710 G16	3748 F15	3805 J 3	3808 G18	5503 D12	6526B D18	6545 D16	6554 E16	6558 B15	6565 E11	
2636 H 5	2664 I 11	2669 E11	2674 H14	2679 I 7	2684 C 6	2689 C 7	2697 H11	3658 F10	3667 C14	3673 I 14	3678 D15	3701 G14	3707 H16	3721 D16	3743 F11	3776 J11	3804 J 3	3804 H15	6519 E14	6541 C 5	6546 D18	6555 F15	6560 C18	
2651 E 9	2665 D11	2669 D13	2675 C14	2680 I 7	2685 D 7	2690 D 7	2698 H14	3661 I 11	3675 D12	3679 I 15	3686 D18	3703 G14	3709 E16	3737 J 9	3745 E11	3801 J 2	3806 J 3	3802 D13	6535B H13	6543 I 16	6552 G14	6556 E15	6563 I 9	
2652 F 9	2666 H12	2670 I 14	2676 H 8	2681 I 7	2686 C 7	2691 D 7	2699 H14	3664 I 11	3670 D12	3675 I 15	3680 D18	3703 G14	3709 E16	3737 J 9	3745 E11	3801 J 2	3806 J 3	3802 D13	6535B H13	6543 I 16	6552 G14	6556 E15	6563 I 9	

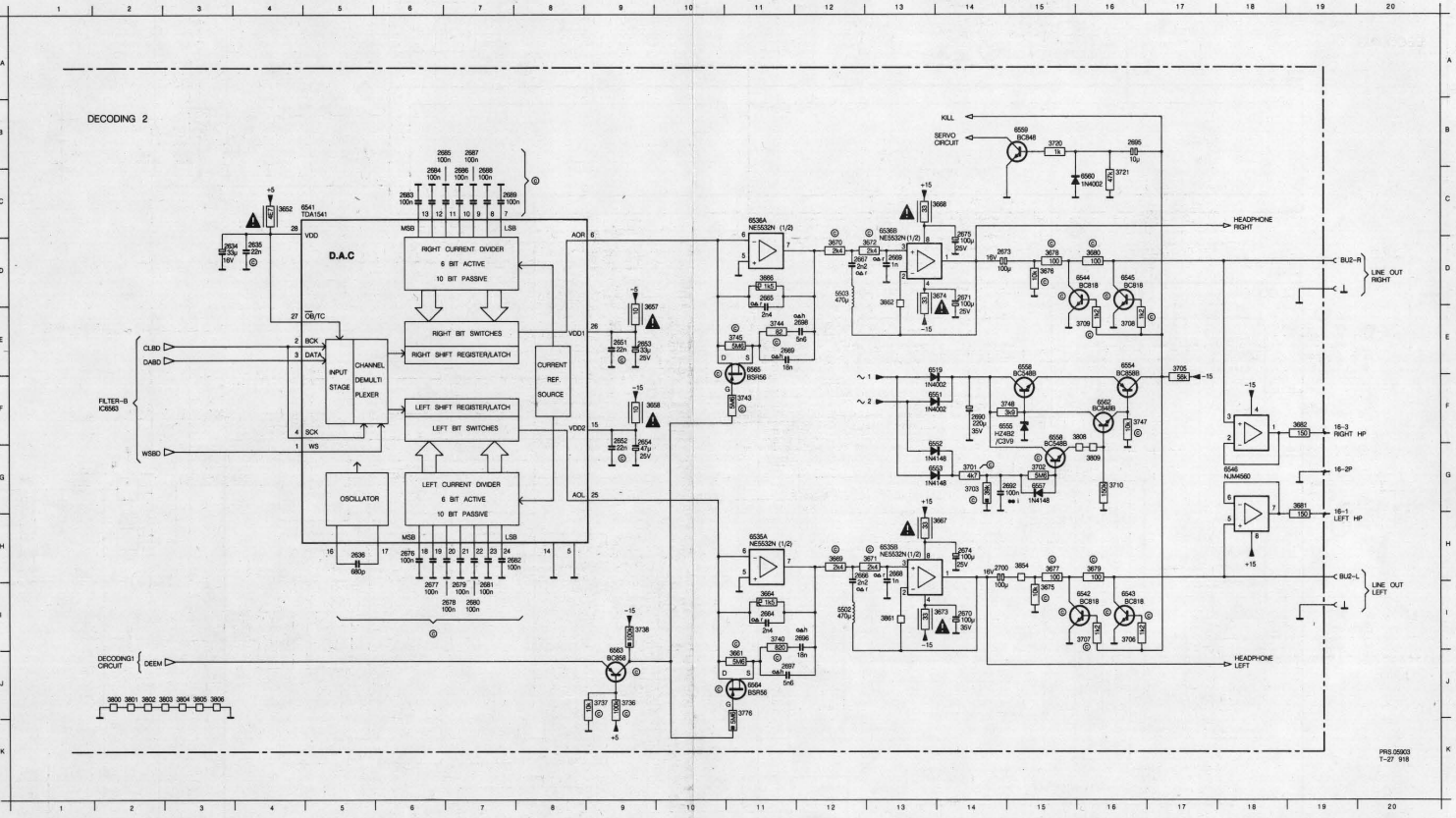

PRS 05903
T-27 918

CD50

VARIABLE LINE OUT

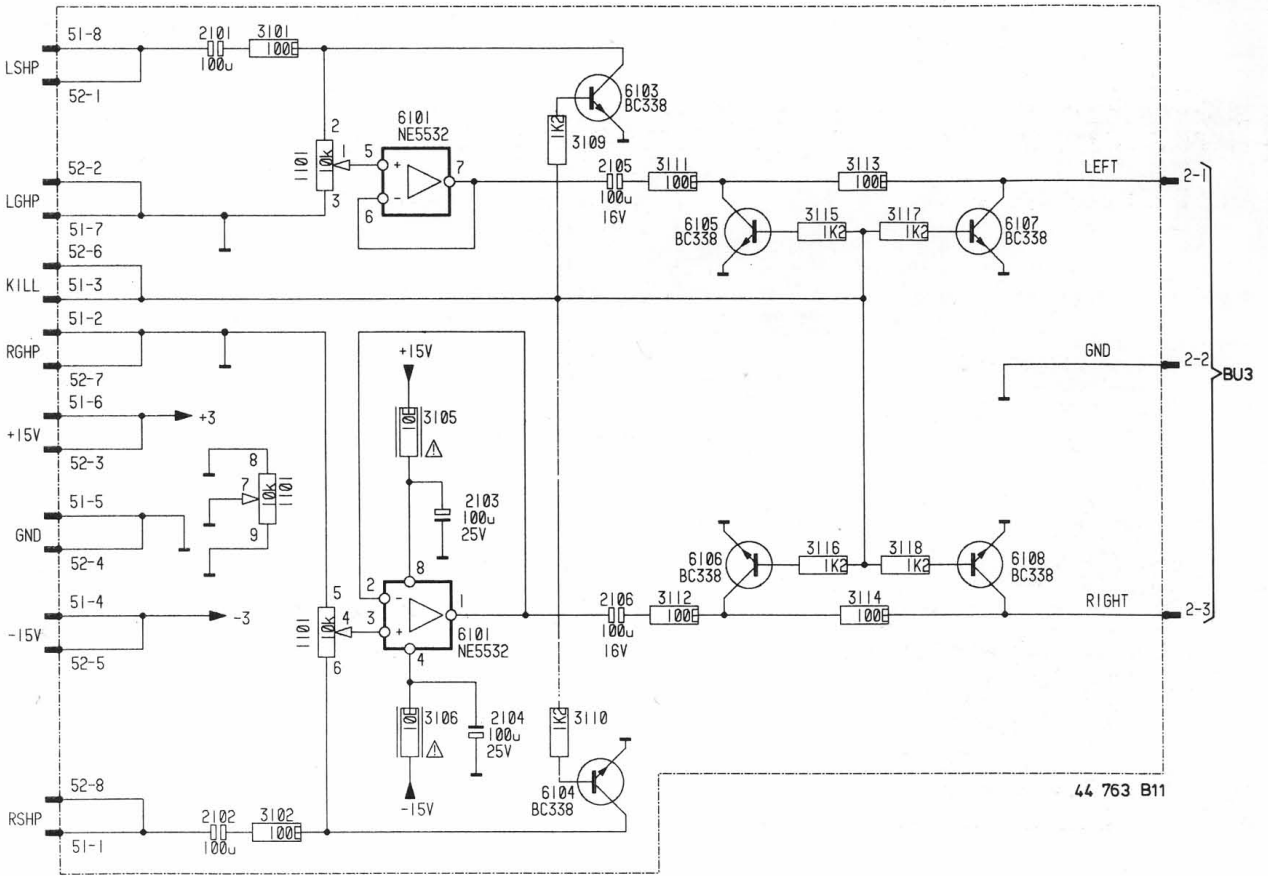

HEADPHONE PANEL

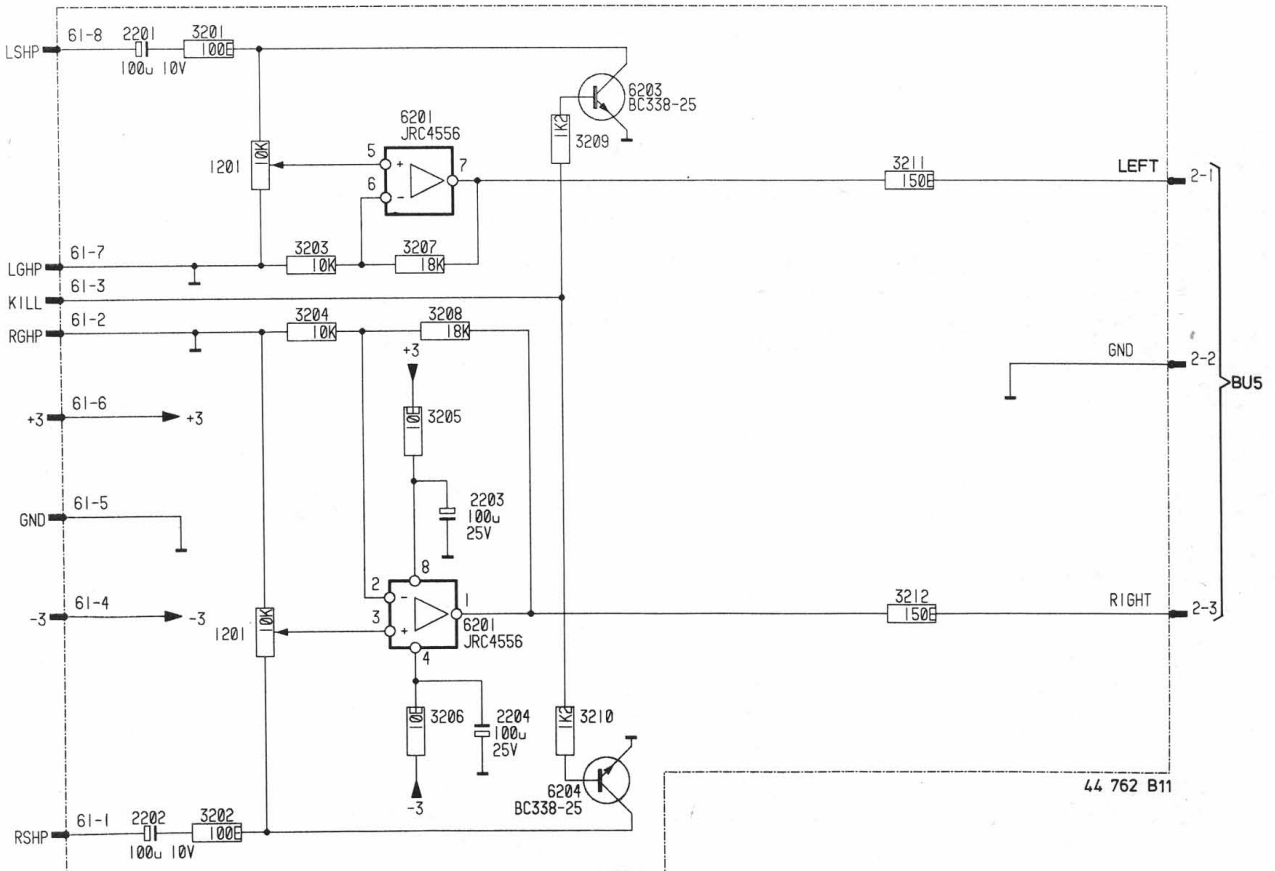

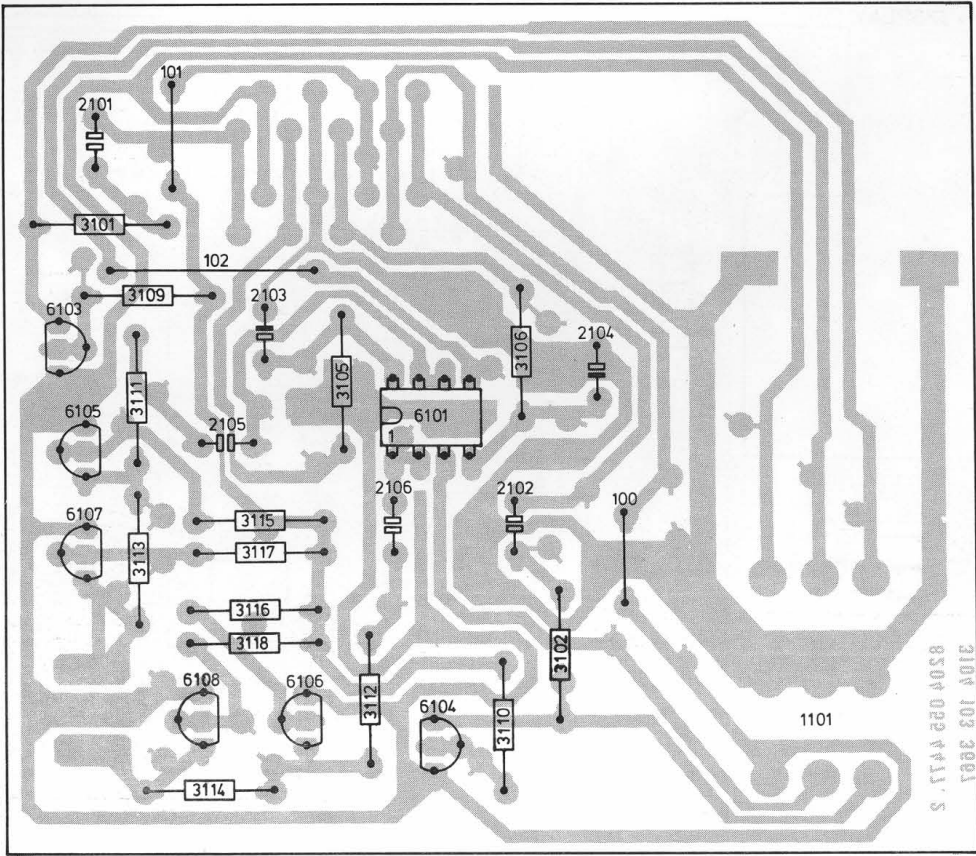

44 766 B11

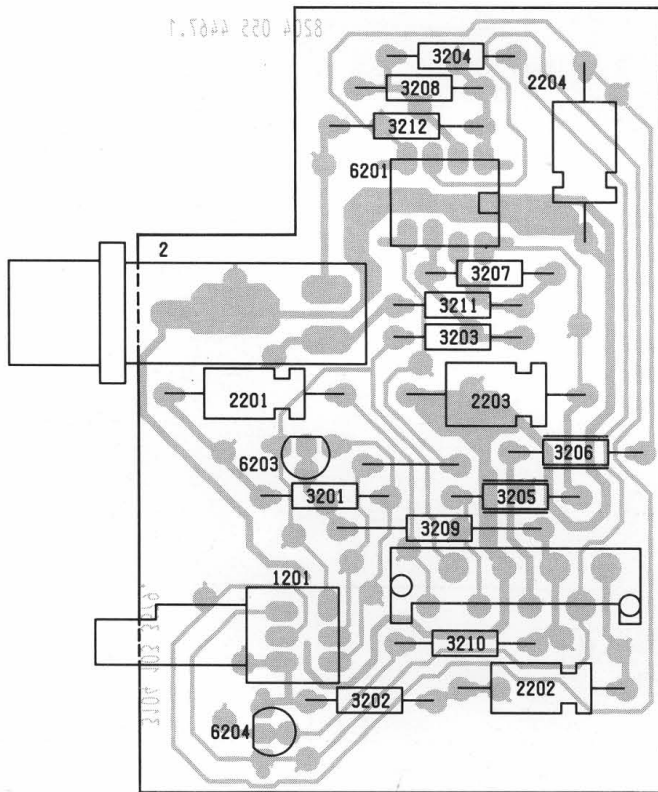

44 772 B11

WIRING DIAGRAM

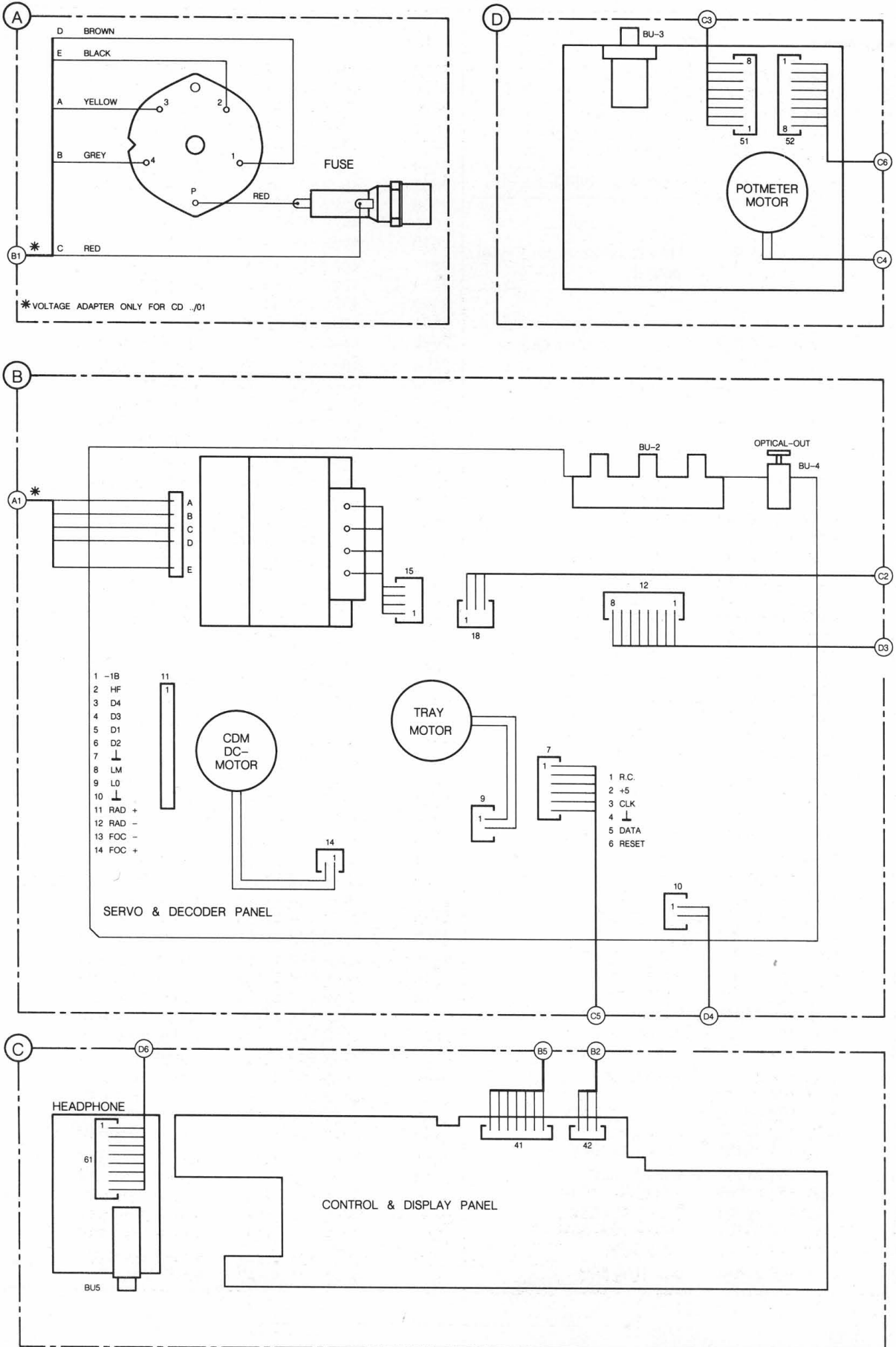

ELECTRICAL PARTSLIST SERVO & DECODER PANEL

Miscellaneous			— —		
BU-1	4822 265 20291	Mains inlet	2572	5322 121 42661	330nF 5% 63V
BU-2	4822 267 20368	Cinch socket 5P	2574	4822 122 31759	18nF 10%
SK-1	4822 276 11309	Mains switch	2600	4822 122 31772	47pF 5% 50V
SK-2	4822 276 12523	Tact switch (4.3mm)	2601	4822 122 31644	2n2 10% 63V
	4822 256 30274	Fuse holder	2602	4822 121 51252	470nF 5% 100V
	4822 492 63076	Clamping spring	2604	4822 124 41576	2μ2 20% 50V
			2607	4822 124 40272	33μF20% 16V
			2608	4822 122 33147	22nF 20%
			2609	4822 122 33147	22nF 20%
			2610	4822 124 20688	33μF 50% 16V
			2611	4822 122 33147	22nF 20%
			2612	4822 124 40272	33μF 20% 16V
			2620	4822 122 33147	22nF 20%
			2621	4822 122 33147	22nF 20%
			2622	4822 124 22031	4μ7 20% 63V
			2623	4822 122 31772	47pF 5% 50V
			2624	4822 122 31772	47pF 5% 50V
			2630	4822 122 31772	47pF 5% 50V
			2631	4822 122 31772	47pF 5% 50V
			2632	4822 124 40272	33μF 20% 16V
			2633	4822 122 33147	22nF 20%
			2634	4822 124 40272	33μF 20% 16V
			2635	4822 122 33147	22nF 20%
			2636	4822 122 31775	680pF 5% 50V
			2638	4822 122 10166	22nF 30% 16V
			2640	4822 122 33147	22nF 20%
			2641	4822 122 32183	56nF 10% 50V
			2642	4822 122 32183	56nF 10% 50V
			2644	4822 122 33147	22nF 20%
			2645	4822 122 33147	22nF 20%
			2646	4822 122 33104	100nF10% 63V
			2651	4822 122 33147	22nF 20%
			2652	4822 122 33147	22nF 20%
			2653	4822 124 40272	33μF 20% 16V
			2654	4822 124 41527	47μF 25V
			2664	4822 121 51111	2n4 2% 250V
			2665	4822 121 51111	2n4 2% 250V
			2668	4822 121 43066	1nF 1% 400V
			2669	4822 121 43066	1nF 1% 400V
			2670	4822 124 41528	100μF 25V
			2671	4822 124 41528	100μF 25V
			2673	4822 124 22339	100μF 20% 16V Bipolar
			2674	4822 124 41528	100μF 25V
			2675	4822 124 41528	100μF 25V
			2676	4822 122 33104	100nF 10% 63V
			2677	4822 122 33104	100nF 10% 63V
			2678	4822 122 33104	100nF 10% 63V
			2679	4822 122 33104	100nF 10% 63V
			2680	4822 122 33104	100nF 10% 63V
			2681	4822 122 33104	100nF 10% 63V
			2682	4822 122 33104	100nF 10% 63V
			2683	4822 122 33104	100nF 10% 63V
			2684	4822 122 33104	100nF 10% 63V
			2685	4822 122 33104	100nF 10% 63V
			2686	4822 122 33104	100nF 10% 63V
			2687	4822 122 33104	100nF 10% 63V
			2688	4822 122 33104	100nF 10% 63V
			2689	4822 122 33104	100nF 10% 63V
			2690	4822 124 41573	470μF 20% 35V
			2691	4822 121 51252	470nF 5% 100V
			2692	5322 121 42386	100nF 5% 63V
			2693	4822 122 33147	22nF 20%
HF-transformer					
1000	4822 148 80281	HF-transformer for Digital output			
Crystal					
1502	4822 242 71349	11.289 600 MHz Quartz Crystal			
1503	4822 242 70831	4.00 MHz Ceramic Resonator			
— —					
2500	4822 126 10005	3n3 400V 20% Ceramic disc cap.			
2501	4822 122 33147	22nF 20%			
2503	4822 122 33147	22nF 20%			
2504	4822 122 31727	470pF 5% 63V			
2506	4822 122 10166	22nF 30% 16V			
2507	4822 122 31644	2n2 10% 63V			
2508	5322 121 42491	47nF 5% 100V			
2509	4822 122 31765	100pF 5% 50V			
2510	4822 122 32442	10nF 50V			
2511	4822 122 31746	1000pF 5% 50V			
2513	4822 121 42245	220nF 10% 63V			
2514	4822 121 51252	470nF 5% 100V			
2515	4822 122 31746	1000pF 5% 50V			
2519	4822 124 22027	47μF 20% 25V			
2520	4822 122 31965	220pF 5% 63V			
2521	4822 124 41527	47μF 25V			
2522	4822 122 33147	22nF 20%			
2523	4822 124 40257	220μF 20% 63V			
2524	4822 122 33147	22nF 20%			
2525	4822 122 33147	22nF 20%			
2526	4822 122 33147	22nF 20%			
2530	4822 121 51321	8μ2 1% 63V			
2531	4822 121 51321	8μ2 1% 63V			
2532	4822 124 40272	33μF 20% 16V			
2534	5322 121 42661	330nF 5% 63V			
2535	5322 122 31848	33nF 10% 63V			
2536	5322 122 31848	33nF 10% 63V			
2537	4822 121 42245	220nF 10% 63V			
2538	4822 121 42245	220nF 10% 63V			
2540	4822 124 41583	0μ68 Bipolar Elco			
2542	4822 122 33147	22nF 20%			
2545	4822 122 33104	100nF 10% 63V			
2546	4822 122 33147	22nF 20%			
2550	5322 121 42491	47nF 5% 100V			
2560	4822 121 51314	4n7 5% 50V			
2561	4822 121 51252	470nF 5% 100V			
2562	5322 121 42661	330nF 5% 63V			
2563	4822 122 33104	100nF 10% 63V			
2566	4822 122 33147	22nF 20%			
2570	4822 122 31644	2n2 10% 63V			



2695	4822 124 41558	10μF 20% 25V Bipolar
2696	4822 121 51225	18nF 2% 63V
2697	4822 121 51361	5n6 2% 160V
2698	4822 121 51361	5n6 2% 160V
2699	4822 121 51225	18nF 2% 63V
2700	4822 124 22339	100μF 20% 16V Bipolar
2702	4822 124 22337	22μF 20% 63V
2703	4822 124 41594	330μF 20% 35V
2704	4822 124 41527	47μF 25V
2705	4822 122 33147	22nF 20%
2706	4822 122 33147	22nF 20%
2707	4822 124 41591	6800μF 20% 16V
2708	4822 124 40272	33μF 20% 16V
2709	4822 122 33147	22nF 20%
2710	4822 122 33147	22nF 20%
2711	4822 124 41571	1000μF 20% 16V
2712	4822 124 40272	33μF 20% 16V
2713	4822 124 41573	470μF 20% 35V
2714	4822 124 41527	47μF 25V
2715	5322 121 42386	100nF 5% 63V



3501	5322 111 90111	4k7 2% 0,125W
3502	4822 111 90214	100k 2% 0,125W
3503	4822 111 30499	4Ω7 5% 0,33W
3504	4822 111 30499	4Ω7 5% 0,33W
3505	4822 111 90253	12k 2% 0,125W
3506	4822 116 52389	100Ω 5% 0,5W
3507	5322 111 90092	1k 2% 0,125W
3508	4822 111 90512	24k 2% 0,125W
3509	4822 111 90572	5k6 2% 0,125W
3510	4822 111 90249	10k 2% 0,125W
3520	4822 101 10685	4k7 20% lin 0,05W trimpot
3521	4822 116 52407	220Ω 5% 0,5W
3522	4822 111 30515	18Ω 5% 0,33W
3523	4822 111 30511	12Ω 5% 0,33W
3524	5322 111 90091	100Ω 2% 0,125W
3533	5322 111 90268	5k1 2% 0,125W
3534	4822 111 90197	220k 2% 0,125W
3535	4822 116 53081	12k 1% 0,6W
3539	4822 111 90251	22k 2% 0,125W
3540	4822 111 30499	4Ω7 5% 0,33W
3541	4822 111 90544	6k8 2% 0,125W
3542	4822 111 90357	33Ω 2% 0,125W
3543	4822 111 90544	6k8 2% 0,125W
3545	4822 111 30483	1Ω 5% 0,33W
3546	4822 111 30483	1Ω 5% 0,33W
3551	5322 111 90099	150k 2% 0,125W
3552	5322 111 90101	1k8 2% 0,125W
3555	4822 111 90238	180k 5% 0,25W
3557	4822 111 90197	220k 2% 0,125W
3560	4822 111 91494	11k 2%
3561	4822 116 90417	150k 2%
3562	4822 111 90568	120k 2% 0,125W
3563	4822 111 90573	56k 2% 0,125W
3564	4822 111 91495	160k 2%
3565	5322 111 90105	27Ω 2% 0,125W
3566	4822 111 90186	22Ω 2% 0,125W
3567	4822 111 90575	82k 2% 0,125W
3568	4822 100 20522	22k 20% lin 0,05W trimpot
3569	4822 111 90368	680k 2% 0,125W
3574	5322 111 90267	33k 2% 0,125W
3575	5322 111 90111	4k7 2% 0,125W
3576	4822 116 52848	200k 1% 0,6W



3578	4822 111 90575	82k 2% 0,125W
3579	4822 116 90417	150k 2%
3580	4822 116 52426	4k7 5% 0,5W
3581	4822 116 53105	3k3 1% 0,6W
3582	4822 111 90572	5k6 2% 0,125W
3584	4822 111 91492	91k 2%
3585	4822 111 90214	100k 2% 0,125W
3586	4822 111 90368	680k 2% 0,125W
3588	4822 116 52472	47k 5% 0,5W
3589	5322 111 90111	4k7 2% 0,125W
3591	5322 111 90096	1k2 2% 0,125W
3600	4822 111 90248	2k2 2% 0,125W
3602	4822 111 90251	22k 2% 0,125W
3603	4822 111 90371	75Ω 2% 0,125W
3604	4822 111 30499	4Ω7 5% 0,33W
3605	5322 111 90265	1k6 2% 0,125W
3607	4822 111 90571	3k9 2% 0,125W
3609	4822 111 30499	4Ω7 5% 0,33W
3610	4822 111 90373	9k1 2% 0,125W
3611	4822 111 90366	620Ω 2% 0,125W
3613	4822 111 90251	22k 2% 0,125W
3621	4822 111 90238	180k 5% 0,25W
3622	4822 111 90543	47k 2% 0,125W
3623	4822 111 90238	180k 5% 0,25W
3624	4822 111 90248	2k2 2% 0,125W
3625	4822 111 90249	10k 2% 0,125W
3626	4822 111 90249	10k 2% 0,125W
3627	4822 111 30499	4Ω7 5% 0,33W
3628	4822 111 90251	22k 2% 0,125W
3629	4822 111 90197	220k 2% 0,125W
3630	4822 111 90251	22k 2% 0,125W
3638	4822 111 90251	22k 2% 0,125W
3639	4822 111 90251	22k 2% 0,125W
3640	4822 111 90251	22k 2% 0,125W
3643	4822 111 90251	22k 2% 0,125W
3645	5322 111 90111	4k7 2% 0,125W
3646	4822 111 90251	22k 2% 0,125W
3647	4822 111 90251	22k 2% 0,125W
3650	4822 111 30483	1Ω 5% 0,33W
3651	4822 111 90197	220k 2% 0,125W
3652	4822 111 30499	4Ω7 5% 0,33W
3653	4822 116 52428	560Ω 5% 0,5W
3654	5322 111 90118	8k2 2% 0,125W
3655	4822 111 30499	4Ω7 5% 0,33W
3657	4822 111 30499	4Ω7 5% 0,33W
3658	4822 111 30508	10Ω 5% 0,33W
3659	4822 116 52426	4k7 5% 0,5W
3665	5322 116 53478	1k5 1% 0,6W
3666	5322 116 53478	1k5 1% 0,6W
3667	4822 111 30522	33Ω 5% 0,33W
3668	4822 111 30522	33Ω 5% 0,33W
3669	4822 116 90271	2k4 2%
3670	4822 116 90271	2k4 2%
3671	4822 116 90271	2k4 2%
3672	4822 116 90271	2k4 2%
3673	4822 111 30522	33Ω 5% 0,33W
3674	4822 111 30522	33Ω 5% 0,33W
3675	4822 111 90249	10k 2% 0,125W
3676	4822 111 90249	10k 2% 0,125W
3677	5322 111 90091	100Ω 2% 0,125W
3678	5322 111 90091	100Ω 2% 0,125W
3679	5322 111 90091	100Ω 2% 0,125W
3680	5322 111 90091	100Ω 2% 0,125W
3690	4822 111 90253	12k 2%



3691	4822 111 90253	12k 2%
3692	4822 111 90253	12k 2%
3693	5322 116 80445	4k7 5%
3694	4822 111 90253	12k 2%
3695	5322 116 80426	100Ω
3696	4822 111 30513	15Ω Safety Resistor
3697	4822 111 30513	15Ω Safety Resistor
3701	5322 111 90111	4k7 2% 0,125W
3702	4822 111 90425	5M6 5% 0,125W
3703	5322 111 90108	39k 2% 0,125W
3704	5322 111 90096	1k2 2% 0,125W
3705	4822 111 90573	56k 2% 0,125W
3706	5322 111 90096	1k2 2% 0,125W
3707	5322 111 90096	1k2 2% 0,125W
3708	5322 111 90096	1k2 2% 0,125W
3710	5322 111 90099	150k 2% 0,125W
3720	5322 111 90092	1k 2% 0,125W
3721	4822 111 90543	47k 2% 0,125W
3722	4822 111 30499	47k 5% 0,33W
3724	4822 116 53081	12k 1% 0,6W
3725	4822 111 90253	12k 2% 0,125W
3726	4822 111 90251	22k 5%
3728	4822 111 90572	5k6 2% 0,125W
3729	4822 116 53081	12k 0423 ER
3730	4822 111 90253	12k 2% 0,125W
3731	4822 111 90186	22Ω 2% 0,125W
3736	4822 111 90214	100k 2% 0,125W
3737	4822 111 90249	10k 2% 0,125W
3738	4822 111 90214	100k 2% 0,125W
3739	4822 111 90425	5M6 5% 0,125W
3740	4822 116 52864	820Ω 1% 0,6W
3743	4822 111 90425	5M6 5% 0,125W
3744	4822 116 52864	820Ω 1% 0,6W
3745	4822 111 90425	5M6 5% 0,125W
3747	4822 111 90249	10k 2% 0,125W
3748	4822 111 90571	3k9 2% 0,125W
3750	4822 116 52391	1k 5% 0,125W
3775	5322 111 90111	4k7 2% 0,125W
3776	4822 111 90425	5M6 5% 0,125W
3779	5322 111 90306	750Ω 2% 0,125W

jumper

3801	4822 111 90163	jumper
3802	4822 111 90163	jumper
3803	4822 111 90163	jumper
3804	4822 111 90163	jumper
3805	4822 111 90163	jumper
3808	4822 111 90163	jumper
3809	4822 111 90163	jumper
3810	4822 111 90163	jumper
3811	4822 111 90163	jumper
3812	4822 111 90163	jumper
3813	4822 111 90163	jumper
3814	4822 111 90163	jumper
3818	4822 111 90163	jumper
3821	4822 111 90163	jumper
3822	4822 111 90163	jumper
3823	4822 111 90163	jumper
3824	4822 111 90163	jumper
3825	4822 111 90163	jumper
3826	4822 111 90163	jumper
3827	4822 111 90163	jumper
3828	4822 111 90163	jumper
3829	4822 111 90163	jumper

jumper

3830	4822 111 90163	jumper
3831	4822 111 90163	jumper
3833	4822 111 90163	jumper
3834	4822 111 90163	jumper
3835	4822 111 90163	jumper
3836	4822 111 90163	jumper
3837	4822 111 90163	jumper
3838	4822 111 90163	jumper
3839	4822 111 90163	jumper
3840	4822 111 90163	jumper
3841	4822 111 90163	jumper
3842	4822 111 90163	jumper
3843	4822 111 90163	jumper
3844	4822 111 90163	jumper
3845	4822 111 90163	jumper
3847	4822 111 90163	jumper
3848	4822 111 90163	jumper
3849	4822 111 90163	jumper
3850	4822 111 90163	jumper
3852	4822 111 90163	jumper
3853	4822 111 90163	jumper
3854	4822 111 90163	jumper
3855	4822 111 90163	jumper
3856	4822 111 90163	jumper
3857	4822 111 90163	jumper
3858	4822 111 90163	jumper
3859	4822 111 90163	jumper
3860	4822 111 90163	jumper
3861	4822 111 90163	jumper
3862	4822 111 90163	jumper



5502	4822 157 53141	coil 470μH
5503	4822 157 53141	coil 470μH

semi conductor



6500	4822 209 72587	TCA0372DP2
6501	4822 209 73234	TDA8808T/C3
6502	4822 130 44121	BC338
6503	4822 209 73235	TDA8809T/C2
6504	4822 209 72587	TCA0372DP2
6505	4822 130 34173	BZX79-B5V6
6506	4822 130 34173	BZX79-B5V6
6510	4822 130 31456	BZV85-C5V1
6512	4822 209 83274	NJM4560D
6516	5322 130 42012	BC858
6517	5322 130 42012	BC858
6519	5322 130 30684	1N4002
6520	4822 130 42131	BF550
6523	4822 209 70422	MN4264-15
6526	4822 130 61207	BC848
6527	5322 130 42012	BC858
6530	4822 209 60801	MC68HC05C9P/SC409009 for CD50, CD60
6531	4822 130 42675	BC818
6535	5322 209 86234	NE5532N
6536	5322 209 86234	NE5532N
6537	5322 130 30684	1N4002
6538	5322 130 30684	1N4002
6540	4822 209 72545	SAA7220P/B
6541	4822 209 72544	TDA1541A/N2
6542	4822 130 42675	BC818

semi conductor			semiconductor		
6543	4822 130 42675	BC818	6569	4822 218 20752	TOTX172 optical transmitter BU-4
6544	4822 130 42675	BC818	6571	4822 209 60772	X24C16
6545	4822 130 42675	BC818	6572	4822 130 34195	BZX55-C13
6547	5322 130 30684	1N4002	6575	4822 130 40823	BD135
6548	5322 130 30684	1N4002	6576	4822 130 40824	BD136
6549	4822 209 60775	SAA7310GP/05	6577	4822 209 80808	MC78M15CT
6550	5322 130 30684	1N4002	6580	5322 130 30684	1N4002
6551	5322 130 30684	1N4002	6581	5322 130 30684	1N4002
6552	4822 130 30621	1N4148	6582	5322 130 30684	1N4002
6553	4822 130 30621	1N4148	6583	5322 130 30684	1N4002
6554	4822 130 42513	BC858C	6584	5322 130 30684	1N4002
6555	4822 130 31981	BZX55-C3V9	6585	5322 130 30684	1N4002
6556	4822 130 61207	BC848	6586	5322 130 30684	1N4002
6557	4822 130 30621	1N4148	6587	5322 130 30684	1N4002
6558	4822 130 44121	BC338	6590	4822 209 80808	MC78M15CT
6559	4822 130 61207	BC848	6591	4822 209 71579	TY40408 = MC7805CT selected
6561	4822 209 60803	SN74LS08D	6592	5322 209 11222	MC7905CT
6562	4822 130 61207	BC848	6593	5322 130 41899	MC7915CT
6563	5322 130 42012	BC858			
6564	4822 130 42633	BSR56			
6565	4822 130 42633	BSR56			
6568	4822 130 61207	BC848			



MISCELLANEOUS

mains voltage			tools		
1501	4822 253 30009	FUSE 160 mA (5X20) only for /01/02/05	TOOLS	4822 397 30155	AUDIO TEST DISC 1kHz (65 min)
1501	4822 253 30014	FUSE 315 mA (5,2X20) only for /04	TOOLS	4822 397 30184	CD AUDIO SIGNALS
1501	4822 253 30217	FUSE 300 mA (5X20) only for /06B	TOOLS	4822 397 60141	AUDIO TEST MAX DIAM
5001	4822 146 30798	MAINSTRANSFORMER only for /01	TOOLS	4822 397 30096	AUDIO TEST DISC 5+5A
5001	4822 146 30778	MAINS-TRANSFORMER only for /02/05	TOOLS	4822 395 50145	TORX SCREWDRIVER SET
5001	4822 146 30782	MAINS-TRANSFORMER only for /04	TOOLS	4822 395 50132	TORX SCREW SQUARE
5001	4822 146 30797	MAINS-TRANSFORMER only for /06B	TOOLS	4822 395 30204	13TH ORDER FILTER
			TOOLS	4822 322 40066	SERVICE CABLE (14P)
			TOOLS	4822 267 50676	SERVICE CONN (14P)
			TOOLS	5322 130 32182	LED GREEN CQYG11
			TOOLS	4822 321 21284	SERVICE CABLE (4P)
miscellaneous					
	4822 600 10295	A-BOX MARANTZ only for /04			
	4822 600 10303	A-BOX MARANTZ only for /01/02/05			
	4822 600 10302	A-BOX PHILIPS only for /06			
	4822 600 10294	EPS-CUSHION			
	4822 263 40054	CAROUSEL ASSY only for /01			



ELECTRICAL PARTSLIST CONTROL & DISPLAY PANEL

switch					
SK..	4822 276 12465	TACT SWITCH	3020	4822 116 52413	2k7 5% 0,5W
miscellaneous			3021	4822 116 52413	2k7 5% 0,5W
1001	4822 130 90663	DISPLAY FV364G	3022	4822 116 52413	2k7 5% 0,5W
1002	4822 214 51772	IR RECEIVER GP1U521X	3023	4822 116 52413	2k7 5% 0,5W
			3024	4822 116 52413	2k7 5% 0,5W
2001	5322 124 21643	22µF 20% 40V	3025	4822 116 52413	2k7 5% 0,5W
2002	4822 122 10166	22nF 30% 16V	3026	4822 116 52375	68Ω 5%
2003	4822 122 31435	470pF 10% 50V	3027	4822 116 52375	68Ω 5%
2004	5322 124 21643	22µF 20% 40V	3028	4822 116 52375	68Ω 5%
2005	4822 122 10166	22nF 30% 16V	3029	4822 116 52375	68Ω 5%
2006	4822 122 10172	220pF 10% 50V	3030	4822 116 52849	220Ω 5%
			3031	5322 116 53728	160Ω 5%
3001	4822 116 52463	22k 5% 0,5W	3032	4822 116 52428	560Ω 5%
3002	4822 116 52463	22k 5% 0,5W	3033	4822 116 52428	560Ω 5%
3003	4822 116 52463	22k 5% 0,5W	3034	4822 116 52428	560Ω 5%
3004	4822 111 30499	4Ω7 5% 0,33W Safety Resistor	3035	4822 116 52428	560Ω 5%
3005	4822 116 52472	47k 5%	semiconductor		
3006	4822 116 52426	4k7 5% 0,5W	6001	4822 209 72226	FTD DRIVER U3090MG
3007	4822 116 52472	47k 5% 0,5W Safety Resistor	6002	4822 130 33732	BZV85-C15
3008	4822 116 52426	4k7 5% 0,5W Safety Resistor	6003	4822 130 30621	1N4148 (FSC)
3009	4822 116 52501	150k 5% 0,5W Safety Resistor	6004	4822 130 40938	BC548
3010	4822 116 52391	1k 5% 0,5W	6006	4822 130 30621	1N4148 (FSC)
3011	4822 116 52391	1k 5% 0,5W	6007	4822 130 30621	1N4148 (FSC)
3012	4822 111 30593	3Ω3 5% 0,33W Safety Resistor	6008	4822 130 30621	1N4148 (FSC)
3013	4822 111 30593	3Ω3 5% 0,33W Safety Resistor	6011	4822 130 30621	1N4148 (FSC)
3015	4822 111 30499	4Ω7 5% 0,33W Safety Resistor	6016	4822 130 34173	BZX55-C5V6
3016	4822 116 52472	47k 5% 0,5W	6017	4822 209 60774	PC74HC75P
3017	4822 116 52413	2k7 5% 0,5W	6018	4822 130 40938	BC548
3018	4822 116 52413	2k7 5% 0,5W	6019	4822 130 40938	BC548
3019	4822 116 52413	2k7 5% 0,5W	6020	4822 130 40938	BC548
			6021	4822 130 40938	BC548
			6022	4822 130 80848	TLHG4499
			6023	4822 130 80848	TLHG4499
			6024	4822 130 80848	TLHG4499
			6025	4822 130 80848	TLHG4499
			6027	4822 130 80848	TLHG4499
			6028	4822 130 30621	1N4148 (FSC)
			6029	4822 130 34173	BZX55-C5V6
			6030	4822 130 34173	BZX55-C5V6

ELECTRICAL PARTSLIST MOTOR VARIABLE LINE OUT PANEL

BU					
BU 3	4822 267 30878	CINCH VARIABLE LINE OUT SOCKET	3110	4822 116 52395	1k2 5% 0,5W
			3111	4822 116 52389	100Ω 5% 0,5W
			3112	4822 116 52389	100Ω 5% 0,5W
			3113	4822 116 52389	100Ω 5% 0,5W
			3114	4822 116 52389	100Ω 5% 0,5W
motor potmeter			3115	4822 116 52395	1k2 5% 0,5W
1101	4822 101 30615	motor potmeter 10kΩ log 20%	3116	4822 116 52395	1k2 5% 0,5W
			3117	4822 116 52395	1k2 5% 0,5W
			3118	4822 116 52395	1k2 5% 0,5W
			semiconductor		
2101	4822 124 22339	100μF 20% 25V	6101	5322 209 86234	NE5532N
2102	4822 124 22339	100μF 20% 25V	6103	4822 130 44121	BC338
2103	4822 124 41528	100μF 25V	6104	4822 130 44121	BC338
2104	4822 124 41528	100μF 25V	6105	4822 130 44121	BC338
2105	4822 124 22339	100μF 20% 25V	6106	4822 130 44121	BC338
2106	4822 124 22339	100μF 20% 25V	6107	4822 130 44121	BC338
			6108	4822 130 44121	BC338
					
3101	4822 116 52389	100Ω 5% 0,5W			
3102	4822 116 52389	100Ω 5% 0,5W			
3105	4822 111 30508	10Ω 5% 0,33W Safety Resistor			
3106	4822 111 30508	10Ω 5% 0,33W Safety Resistor			
3109	4822 116 52395	1k2 5% 0,5W			

ELECTRICAL PARTSLIST HEADPHONE PANEL

BU					
BU 5	4822 267 31065	HEADPHONE SOCKET only for /01B/02B/04B/05B/06B	3206	4822 111 30508	10Ω 5% 0,33W Safety Resistor
BU 5	4822 267 31106	HEADPHONE SOCKET only for /02G/04G	3207	4822 116 52461	18k 5% 0,5W
			3208	4822 116 52461	18k 5% 0,5W
miscellaneous			3209	4822 116 52395	1k2 5% 0,5W
1201	4822 102 10398	dual potmeter 10kΩ log	3210	4822 116 52395	1k2 5% 0,5W
			3211	4822 116 52398	150Ω 5% 0,5W
			3212	4822 116 52398	150Ω 5% 0,5W
			semiconductor		
2201	5322 124 21762	100μF 20% 10V	6201	4822 209 82362	NJM4556D
2202	5322 124 21762	100μF 20% 10V	6203	4822 130 44121	BC338
2203	5322 124 21711	100μF 20% 25V	6204	4822 130 44121	BC338
2204	5322 124 21711	100μF 20% 25V			
					
3201	4822 116 52389	100Ω 5% 0,5W			
3202	4822 116 52389	100Ω 5% 0,5W			
3203	4822 116 52452	10k 5% 0,5W			
3204	4822 116 52452	10k 5% 0,5W			
3205	4822 111 30508	10Ω 5% 0,33W Safety Resistor			

Ⓢ Chips 50 V NP0 S1206			Ⓢ Chips 0,125 W S1206			Ⓢ Chips 0,125 W S1206			1U
1 pF	5%	4822 122 32479	4,7 E	5%	5322 111 90376	6,8 k	2%	4822 111 90544	
1,2 pF	5%	4822 122 33013	5,1 E	5%	4822 111 90393	7,5 k	2%	4822 111 90276	
1,5 pF	5%	4822 122 31792	5,6 E	5%	4822 111 90394	8,2 k	2%	5322 111 90118	
1,8 pF	5%	4822 122 32087	6,2 E	5%	4822 111 90395	9,1 k	2%	4822 111 90373	
2,2 pF	5%	4822 122 32425	6,8 E	5%	4822 111 90254	10 k	2%	4822 111 90249	
3,3 pF	5%	4822 122 32079	7,5 E	5%	4822 111 90396	11 k	2%	4822 111 90337	
3,9 pF	5%	4822 122 32081	8,2 E	5%	4822 111 90397	12 k	2%	4822 111 90253	
4,7 pF	5%	4822 122 32082	9,1 E	5%	4822 111 90398	13 k	2%	4822 111 90509	
5,6 pF	5%	4822 122 32506	10 E	2%	5322 111 90095	15 k	2%	4822 111 90196	
6,8 pF	5%	4822 122 32507	11 E	2%	4822 111 90338	16 k	2%	4822 111 90346	
8,2 pF	5%	4822 122 32083	12 E	2%	4822 111 90341	18 k	2%	4822 111 90238	
10 pF	5%	4822 122 31971	13 E	2%	4822 111 90343	20 k	2%	4822 111 90349	
12 pF	5%	4822 122 32139	15 E	2%	4822 111 90344	22 k	2%	4822 111 90251	
15 pF	5%	4822 122 32504	16 E	2%	4822 111 90347	24 k	2%	4822 111 90512	
18 pF	5%	4822 122 31769	18 E	2%	5322 111 90139	27 k	2%	4822 111 90542	
22 pF	10%	4822 122 31837	20 E	2%	4822 111 90352	30 k	2%	4822 111 90216	
27 pF	5%	4822 122 31966	22 E	2%	4822 111 90186	33 k	2%	5322 111 90267	
33 pF	5%	4822 122 31756	24 E	2%	4822 111 90355	36 k	2%	4822 111 90514	
39 pF	5%	4822 122 31972	27 E	2%	5322 111 90105	39 k	2%	5322 111 90108	
47 pF	5%	4822 122 31772	30 E	2%	4822 111 90356	43 k	2%	4822 111 90363	
56 pF	5%	4822 122 31774	33 E	2%	4822 111 90357	47 k	2%	4822 111 90543	
68 pF	5%	4822 122 31961	36 E	2%	4822 111 90359	51 k	2%	5322 111 90274	
82 pF	10%	4822 122 31839	39 E	2%	4822 111 90361	56 k	2%	4822 111 90573	
100 pF	5%	4822 122 31765	43 E	2%	5322 116 90125	62 k	2%	5322 111 90275	
120 pF	5%	4822 122 31766	47 E	2%	4822 111 90217	68 k	2%	4822 111 90202	
150 pF	5%	4822 122 31767	51 E	2%	4822 111 90365	75 k	2%	4822 111 90574	
180 pF	2%	4822 122 31794	56 E	2%	4822 111 90239	82 k	2%	4822 111 90575	
220 pF	5%	4822 122 31965	62 E	2%	4822 111 90367	91 k	2%	5322 111 90277	
270 pF	5%	4822 122 32142	68 E	2%	4822 111 90203	100 k	2%	4822 111 90214	
330 pF	10%	4822 122 31642	75 E	2%	4822 111 90371	110 k	2%	5322 111 90269	
390 pF	5%	4822 122 31771	82 E	2%	4822 111 90124	120 k	2%	4822 111 90568	
470 pF	5%	4822 122 31727	91 E	2%	4822 111 90375	130 k	2%	4822 111 90511	
560 pF	5%	4822 122 31773	100 E	2%	5322 111 90091	150 k	2%	5322 111 90099	
680 pF	5%	4822 122 31775	110 E	2%	4822 111 90335	160 k	2%	5322 111 90264	
820 pF	5%	4822 122 31974	120 E	2%	4822 111 90339	180 k	2%	4822 111 90565	
1 nF	10%	5322 122 31647	130 E	2%	4822 111 90164	200 k	2%	4822 111 90351	
1,2 nF	5%	4822 122 31807	150 E	2%	5322 111 90098	220 k	2%	4822 111 90197	
1,5 nF	10%	4822 122 31781	160 E	2%	4822 111 90345	240 k	2%	4822 111 90215	
1,8 nF	10%	4822 122 32153	180 E	2%	5322 111 90242	270 k	2%	4822 111 90302	
2,2 nF	10%	4822 122 31644	200 E	2%	4822 111 90348	300 k	2%	5322 111 90266	
2,7 nF	10%	4822 122 31783	220 E	2%	4822 111 90178	330 k	2%	4822 111 90513	
3,3 nF	10%	4822 122 31969	240 E	2%	4822 111 90353	360 k	2%	4822 111 90515	
3,9 nF	10%	4822 122 32566	270 E	2%	4822 111 90154	390 k	2%	4822 111 90182	
4,7 nF	10%	4822 122 31784	300 E	2%	4822 111 90156	430 k	2%	4822 111 90168	
5,6 nF	10%	4822 122 31916	330 E	2%	5322 111 90106	470 k	2%	4822 111 90161	
6,8 nF	10%	4822 122 31976	360 E	1%	4822 111 90288	510 k	2%	4822 111 90364	
10 nF	10%	4822 122 31728	360 E	2%	4822 111 90358	560 k	2%	4822 111 90169	
12 nF	10%	5322 122 31648	390 E	2%	5322 111 90138	620 k	2%	4822 111 90213	
15 nF	10%	4822 122 31782	430 E	2%	4822 111 90362	680 k	2%	4822 111 90368	
18 nF	10%	4822 122 31759	470 E	2%	5322 111 90109	750 k	2%	4822 111 90369	
22 nF	10%	4822 122 31797	510 E	2%	4822 111 90245	820 k	2%	4822 111 90205	
27 nF	10%	4822 122 32541	560 E	2%	5322 111 90113	910 k	2%	4822 111 90374	
33 nF	10%	4822 122 31981	620 E	2%	4822 111 90366	1 M	2%	4822 111 90252	
47 nF	10%	4822 122 32542	680 E	2%	4822 111 90162	1,1 M	5%	4822 111 90408	
56 nF	10%	4822 122 32183	750 E	2%	5322 111 90306	1,2 M	5%	4822 111 90409	
100 nF	10%	4822 122 31947	820 E	2%	4822 111 90171	1,3 M	5%	4822 111 90411	
180 nF	10%	4822 122 32915	910 E	2%	4822 111 90372	1,5 M	5%	4822 111 90412	
220 nF	20%	4822 122 32715	1 k	2%	5322 111 90092	1,6 M	5%	4822 111 90413	
Ⓢ Chips 0,125 W S1206 NP0			1,1 k	2%	4822 111 90336	1,8 M	5%	4822 111 90414	
0 E	jumper	4822 111 90163	1,2 k	2%	5322 111 90096	2 M	5%	4822 111 90415	
1 E	5%	4822 111 90184	1,3 k	2%	4822 111 90244	2,2 M	5%	4822 111 90185	
1,1 E	5%	4822 111 90377	1,5 k	2%	4822 111 90151	2,4 M	5%	4822 111 90416	
1,2 E	5%	4822 111 90378	1,6 k	2%	5322 111 90265	2,7 M	5%	4822 111 90417	
1,3 E	5%	4822 111 90379	1,8 k	2%	5322 111 90101	3 M	5%	4822 111 90418	
1,5 E	5%	4822 111 90381	2 k	2%	4822 111 90165	3,3 M	5%	4822 111 90191	
1,6 E	5%	4822 111 90382	2,2 k	2%	4822 111 90248	3,6 M	5%	4822 111 90419	
1,8 E	5%	4822 111 90383	2,4 k	2%	4822 111 90289	3,9 M	5%	4822 111 90421	
2 E	5%	4822 111 90384	2,7 k	2%	4822 111 90569	4,3 M	5%	4822 111 90422	
2,2 E	5%	5322 111 90104	3 k	2%	4822 111 90198	4,7 M	5%	4822 111 90423	
2,4 E	5%	4822 111 90385	3,3 k	2%	4822 111 90157	5,1 M	5%	4822 111 90424	
2,7 E	5%	4822 111 90386	3,6 k	2%	5322 111 90107	5,6 M	5%	4822 111 90425	
3 E	5%	4822 111 90387	3,9 k	2%	4822 111 90571	6,2 M	5%	4822 111 90426	
3,3 E	5%	4822 111 90388	4,3 k	2%	4822 111 90167	6,8 M	5%	4822 111 90235	
3,6 E	5%	4822 111 90389	4,7 k	2%	5322 111 90111	7,5 M	5%	4822 111 90427	
3,9 E	5%	4822 111 90391	5,1 k	2%	5322 111 90268	8,2 M	5%	4822 111 90237	
4,3 E	5%	4822 111 90392	5,6 k	2%	4822 111 90572	9,1 M	5%	4822 111 90428	
			6,2 k	2%	4822 111 90545	10 M	5%	5322 111 91141	

SYMBOL	DESCRIPTION
	Capacitor, general
	Electrolytic capacitor (+ and - may be omitted)
	Bipolar electrolytic capacitor (+ may be omitted)
	Resistor, general
	N.T.C. resistor
	P.T.C. resistor
	Voltage divider with preset adjustment
	Chip jumper
	Pin contact
	Bus contact
	Coil, self-induction
	Transformer with electrically poor conducting core and adjustable pre-magnetization
	Diode
	Zener diode
	Stabistor
	Double variable capacity diode (in one envelope)
	Photo conductive diode
	L.E.D.

SYMBOL	DESCRIPTION
	Transistor (N.P.N.)
	Transistor (P.N.P.)
	Direct current (DC)
	Alternating current (AC)
	Earth (functional)
	Frame or chassis connection
	Direction in which AC voltages are passed on (optional present)
	Interrupted line
	Not-connected crossing lines
	Connected lines
	Cable tree with lead-outs
	Changer, general (arrow is optional)
	Voltage Controlled Oscillator
	Band-pass filter
	Phase changing network
	Delay element
	Amplifier, general

SYMBOL	DESCRIPTION
	Operational amplifier
	Differential amplifier
	Splitter
	Operational amplifier with open output
	Exclusive OR gate
	True/complement amplifier with high input
	Flip Flop
	AND gate
	OR gate
	Inverter with high input

	0.2W (CR 16)	≧ 220k Ω ≧ 270k Ω	5% 10%
	0.33W (CR 25)	≧ 1M Ω ≧ 1M Ω	5% 10%
	0.33W (SFR25)		5%
	0.25W (VR 25)	≧ 10M Ω ≧ 10M Ω	5% 10%
	0.5W (CR 37)	≧ 1M Ω ≧ 1M Ω	5% 10%
	0.67W (CR 52)		5%
	1.15W (CR 68)		5%
	Ceramic plate		
	Polyester flat foil		
	Polyester mepolesco		
	Mylar (Polyester flat foil small sized)		
	Micropoco		
	Tubular ceramic (body colour pink or yellow/green)		
	Miniature single elco		
	Subminiature tantalum		
			<p>* a=2.5V b=4V c=6.3V d=10V e=16V f=25V g=40V h=63V i=100V j=125V l=125V m=150V n=160V q=200V r=250V s=300V t=350V u=400V v=500V w=630V x=1000V A=1.6V B=6V C=12V D=15V E=20V F=35V G=50V H=75V I=80V</p>